

Leoncino
Benelli

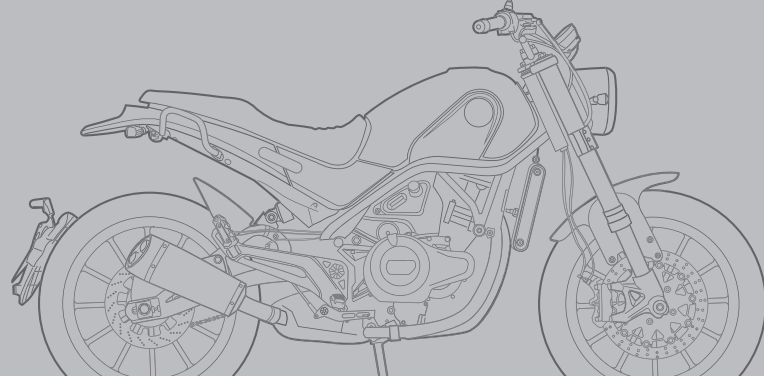

LEONCINO - LEONCINO TRAIL
OWNER'S MANUAL





Owner's Manual

Read this manual carefully before operating this vehicle. This manual should stay with this vehicle if it is sold.

Welcome to the Benelli world of motorcycling!

Please take the time to read this manual thoroughly, so as to enjoy all advantages of your LEONCINO/LEONCINO TRAIL. This Owner's Manual does not only instruct you in how to operate, inspect, and maintain your motorcycle, but also in how to safeguard yourself and others from trouble and injury.

In addition, the many tips given in this manual will help keep your motorcycle in the best possible condition.

If you have any further questions, do not hesitate to contact your Benelli dealer.

The Benelli team wishes you many safe and pleasant rides. So, remember to put safety first!

Benelli continually seeks advancements in product design and quality. Therefore, while this manual contains the most current product information available at the time of printing, there may be minor discrepancies between your motorcycle and this manual. If there is any question concerning this manual, please consult a Benelli dealer.



WARNING

Please read this manual carefully and completely before operating this motorcycle.

Introduction

Particularly important information is distinguished in this manual by the following notations:



This is the safety alert symbol. It is used to alert you to potential personal injury hazards. Obey all safety messages that follow this symbol to avoid possible injury or death.



A WARNING indicates a hazardous situation which, if not avoided, could result in death or serious injury.

NOTICE

A NOTICE indicates special precautions that must be taken to avoid damage to the vehicle or other property.

TIP

A TIP provides key information to make procedures easier or clearer.

Product and specifications are subject to change without notice.

**LEONCINO/LEONCINO TRAIL
OWNER'S MANUAL
Benelli Q.J. s.r.l.
5th edition, 2020
All rights reserved.
Any reprinting or unauthorized use
without the written permission of
Benelli Q.J. s.r.l.
is expressly prohibited.
Distributed by SSR Motorsports**

Table of Contents

Safety information1-1

Description..... 2-1

- Left view..... 2-1
- Right view..... 2-2
- Controls and instruments.....2-3

Instrument and control functions..... 3-1

- Key..... 3-1
- Ignition switch/steering lock.....3-1
- Multi-function meter unit and Indicator lights and warning lights.....3-3
- Handlebar switches..... 3-7
- Clutch lever3-9
- Shift lever.....3-9
- Brake lever.....3-9
- Brake pedal3-10
- ABS.....3-10
- Fuel tank cap..... 3-12
- Fuel..... 3-12
- Catalytic converter3-14
- Seat..... 3-14
- Adjusting the headlight beams 3-15
- Adjusting the shock absorber assembly.....3-15
- Adjusting the front fork..... 3-16
- Sidestand 3-17
- Ignition circuit cut-off system..... 3-17

For your safety – pre-operation checks 4-1

Operation and important riding points.....5-1

- Starting the engine..... 5-1
- Shifting..... 5-2
- Tips for reducing fuel consumption.....5-2
- Engine break-in.....5-3
- Parking..... 5-3

Periodic maintenance and adjustment.....6-1

- Owner's tool kit.....6-2
- General maintenance and lubrication chart..... 6-3
- Checking the spark plugs..... 6-9
- Canister..... 6-10
- Engine oil and oil filter cartridge6-10
- Coolant.....6-13
- Air filter element..... 6-15
- Checking the engine idling speed..... 6-15
- Checking the throttle grip free play.....6-16
- Valve clearance..... 6-16
- Tires 6-16
- Adjusting the clutch lever free play6-18
- Checking the brake

- lever free play 6-19
- Brake light switches..... 6-19
- Checking the front and rear brake pads..... 6-20
- Checking the brake fluid level6-20
- Changing the brake fluid..... 6-21
- Drive chain slack..... 6-22
- Cleaning and lubricating the drive chain..... 6-23
- Checking and lubricating the cables..... 6-24
- Checking and lubricating the throttle grip and cable..... 6-24
- Checking and lubricating the brake and shift pedals..... 6-24
- Checking and lubricating the brake and clutch levers.....6-25
- Checking and lubricating the sidestand..... 6-26
- Checking the front fork..... 6-26
- Checking the steering..... 6-27
- Checking the wheel bearings.... 6-28
- Battery 6-28
- Replacing the fuses..... 6-30
- Brake/tail light and the turn signal light 6-31
- Auxiliary lights..... 6-31
- Troubleshooting..... 6-31
- Troubleshooting charts 6-33

Motorcycle care and storage.....	7-1
• Matte color caution.....	7-1
• Care.....	7-1
• Storage.....	7-3
Specifications.....	8-1
• Electrical System.....	8-4
Consumer information.....	9-1
• Identification numbers.....	9-1
• Diagnostic connector.....	9-2
• Vehicle data recording.....	9-2
Regular maintenance coupons.....	10-1
Emissions Control System Warranty	10-6

Be a Responsible Owner

As the vehicle's owner, you are responsible for the safe and proper operation of your motorcycle.

Motorcycles are single-track vehicles.

Their safe use and operation are dependent upon the use of proper riding techniques as well as the expertise of the operator.

Every operator should know the following requirements before riding this motorcycle.

He or she should:

- Obtain thorough instructions from a competent source on all aspects of motorcycle operation.
- Observe the warnings and maintenance requirements in this Owner's Manual.
- Obtain qualified training in safe and proper riding techniques.
- Obtain professional technical service as indicated in this Owner's Manual and/or when made necessary by mechanical conditions.
- Never operate a motorcycle without proper training or instruction. Take a training course. Beginners should receive training from a certified instructor. Contact an authorized motorcycle dealer to find out about the training courses nearest you.

Safe Riding

Perform the pre-operation checks each time you use the vehicle to make sure it is in safe operating condition. Failure to inspect or maintain the vehicle properly increases the possibility of an accident or equipment damage. See page 4-1 for a list of pre-operation checks.

- This motorcycle is designed to carry the operator and a passenger.
- The failure of motorists to detect and recognize motorcycles in traffic is the predominating cause of automobile/motorcycle accidents. Many accidents have been caused by an automobile driver who did not see the motorcycle. Making yourself conspicuous appears to be very effective in reducing the chance of this type of accident. Therefore:
 - Wear a brightly colored jacket.
 - Use extra caution when you are approaching and passing through intersections, since intersections are the most likely places for motorcycle accidents to occur.
 - Ride where other motorists can see you. Avoid riding in another motorist's blind spot.
 - Never maintain a motorcycle without proper knowledge. Contact an authorized motorcycle dealer to inform you on basic motorcycle maintenance.

Certain maintenance can only be carried out by certified staff.

- Many accidents involve inexperienced operators. In fact, many operators who have been involved in accidents do not even have a current motorcycle license.
 - Make sure that you are qualified and that you only lend your motorcycle to other qualified operators.
 - Know your skills and limits. Staying within your limits may help you to avoid an accident.
 - We recommend that you practice riding your motorcycle where there is no traffic until you have become thoroughly familiar with the motorcycle and all of its controls.
- Many accidents have been caused by error of the motorcycle operator. A typical error made by the operator is veering wide on a turn due to excessive speed or undercornering (insufficient lean angle for the speed).
 - Always obey the speed limit and never travel faster than warranted by road and traffic conditions.
 - Always signal before turning or changing lanes. Make sure that other motorists can see you.
- The posture of the operator and

Safety information

passenger is important for proper control.

- The operator should keep both hands on the handlebar and both feet on the operator footrests during operation to maintain control of the motorcycle.
- The passenger should always hold onto the operator, the seat strap or grab bar, if equipped, with both hands and keep both feet on the passenger footrests. Never carry a passenger unless he or she can firmly place both feet on the passenger footrests.
- Never ride under the influence of alcohol or other drugs.
- This motorcycle is designed for on-road use only. It is not suitable for off-road use.

Protective Apparel

The majority of fatalities from motorcycle accidents are the result of head injuries. The use of a safety helmet is the single most critical factor in the prevention or reduction of head injuries.

- Always wear an approved helmet.
- Wear a face shield or goggles. Wind in your unprotected eyes could contribute to an impairment of vision that could delay

seeing a hazard.

- The use of a jacket, heavy boots, trousers, gloves, etc., is effective in preventing or reducing abrasions or lacerations.
- Never wear loose-fitting clothes, otherwise they could catch on the control levers, footrests, or wheels and cause injury or an accident.
- Always wear protective clothing that covers your legs, ankles, and feet. The engine and exhaust system become very hot during or after operation and can cause burns.
- A passenger should also observe the above precautions.

Avoid Carbon Monoxide Poisoning

All engine exhaust contains carbon monoxide, a deadly gas. Breathing carbon monoxide can cause headaches, dizziness, drowsiness, nausea, confusion, and eventually death. Carbon Monoxide is a colorless, odorless, tasteless gas which may be present even if you do not see or smell any engine exhaust. Deadly levels of carbon monoxide can collect rapidly and you can quickly be overcome and unable to save yourself.

Also, deadly levels of carbon monoxide can linger for hours or days in enclosed or poorly ventilated areas. If you experience

any symptoms of carbon monoxide poisoning, leave the area immediately, get fresh air, and SEEK MEDICAL TREATMENT.

- Do not run engine indoors. Even if you try to ventilate engine exhaust with fans or open windows and doors, carbon monoxide can rapidly reach dangerous levels.
- Do not run engine in poorly ventilated or partially enclosed areas such as barns, garages, or carports.
- Do not run engine outdoors where engine exhaust can be drawn into a building through openings such as windows and doors.

Loading

Adding accessories or cargo to your motorcycle can adversely affect stability and handling if the weight distribution of the motorcycle is changed. To avoid the possibility of an accident, use extreme caution when adding cargo or accessories to your motorcycle.

Use extra care when riding a motorcycle that has added cargo or accessories. Here, along with the information about accessories below, are some general guidelines to follow if loading cargo to your motorcycle:

The total weight of the operator, passen-

ger, accessories and cargo must not exceed the maximum load limit.

Operation of an overloaded vehicle could cause an accident.

Maximum load:
190 Kg / 419 lbs.

When loading within this weight limit, keep the following in mind:

- Cargo and accessory weight should be kept as low and close to the motorcycle as possible. Securely pack your heaviest items as close to the center of the vehicle as possible and make sure to distribute the weight as evenly as possible on both sides of the motorcycle to minimize imbalance or instability.
- Shifting weights can create a sudden imbalance. Make sure that accessories and cargo are securely attached to the motorcycle before riding. Check accessory mounts and cargo restraints frequently.
 - Properly adjust the suspension for your load (suspension-adjustable models only), and check the condition and pressure of your tires.
 - Never attach any large or heavy items to the handlebar,

front fork, or front fender. These items, including such cargo as sleeping bags, duffel bags, or tents, can create unstable handling or a slow steering response.

- **This vehicle is not designed to pull a trailer or to be attached to a sidecar.**

Genuine Benelli Accessories

Choosing accessories for your vehicle is an important decision.

Genuine Benelli accessories, which are available only from a Benelli dealer, have been designed, tested, and approved by Benelli for use on your vehicle.

Many companies with no connection to Benelli manufacture parts and accessories or offer other modifications for Benelli vehicles.

Benelli is not in a position to test the products that these aftermarket companies produce.

Therefore, Benelli can neither endorse nor recommend the use of accessories not sold by Benelli or modifications not specifically recommended by Benelli, even if sold and installed by a Benelli dealer.

Aftermarket Parts, Accessories, and Modifications

While you may find aftermarket products similar in design and quality to genuine Benelli accessories, recognize that some aftermarket accessories or modifications are not suitable because of potential safety hazards to you or others.

Installing aftermarket products or having other modifications performed to your vehicle that change any of the vehicle's design or operation characteristics can put you and others at greater risk of serious injury or death.

You are responsible for injuries related to changes in the vehicle.

Keep the following guidelines in mind, as well as those provided under "Loading" when mounting accessories.

- Never install accessories or carry cargo that would impair the performance of your motorcycle. Carefully inspect the accessory before using it to make sure that it does not in any way reduce ground clearance or cornering clearance, limit suspension travel, steering travel or control operation, or obscure lights or reflectors.
 - Accessories fitted to the handlebar or the front fork area can create instability due to improper weight distribution or aerodynamic changes. If accessories are added to the handlebar or front fork area, they

Safety information

must be and should be kept to a minimum.

- Bulky or large accessories may seriously affect the stability of the motorcycle due to aerodynamic effects. Wind may attempt to lift the motorcycle, or the motorcycle may become unstable in cross winds. These accessories may also cause instability when passing or being passed by large vehicles.
- Certain accessories can displace the operator from his or her normal riding position. This improper position limits the freedom of movement of the operator and may limit control ability, therefore, such accessories are not recommended.
- Use caution when adding electrical accessories. If electrical accessories exceed the capacity of the motorcycle's electrical system, an electric failure could result, which could cause a dangerous loss of lights or engine power.

Aftermarket Tires and Rims

The tires and rims that came with your motorcycle were designed to match the performance capabilities and to provide the best combination of handling, braking, and comfort.

Other tires, rims, sizes, and combinations may not be appropriate. Refer to page 6-16 for tire specifications and more information on replacing your tires.

Transporting the Motorcycle

Be sure to observe following instructions before transporting the motorcycle in another vehicle.

- Remove all loose items from the motorcycle.
- Check that the fuel cock (if equipped) is in the "☒" position and that there are no fuel leaks.
- Point the front wheel straight ahead on the trailer or in the truck bed, and choke it in a rail to prevent movement.
- Shift the transmission in gear (for models with a manual transmission).
- Secure the motorcycle with tie-downs or suitable straps that are attached to solid parts of the motorcycle, such as the frame or upper front fork triple clamp (and not, for example, to rubber-mounted handlebars or turn signals, or parts that could break). Choose the location

for the straps carefully so the straps will not rub against painted surfaces during transport.

- The suspension should be compressed somewhat by the tie-downs, if possible, so that the motorcycle will not bounce excessively during transport.

NOTES

.....

.....

.....

.....

.....

.....

.....

.....

Description

Left view

1. Rear brake fluid reservoir
2. Battery
3. Fuse box
4. Seat lock
5. Coolant drain bolt
6. Shift lever
7. Engine oil drain bolt
8. Engine oil filter cartridge
9. Air filter

ON-ROAD VERSION

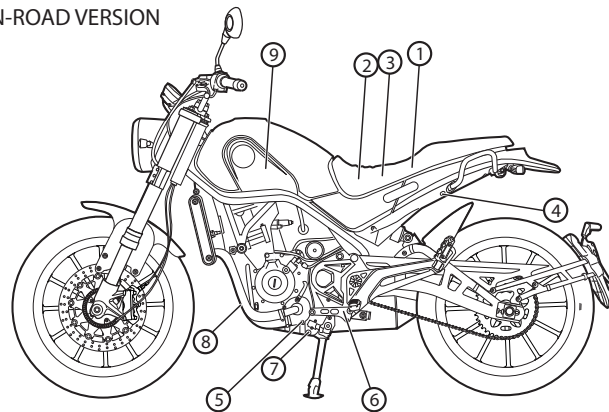

OFF-ROAD VERSION

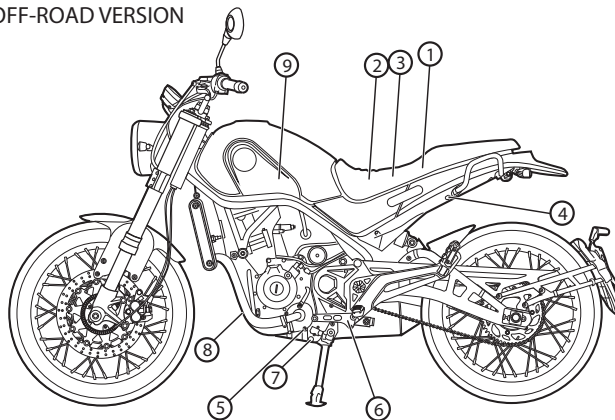

Right view

- 1. Shock absorber
- 2. Fuel tank cap
- 3. Headlight
- 4. Radiator cap
- 5. Engine oil level check window
- 6. Coolant reservoir
- 7. Engine oil filler cap
- 8. Brake pedal
- 9. Brake/tail light

ON-ROAD VERSION

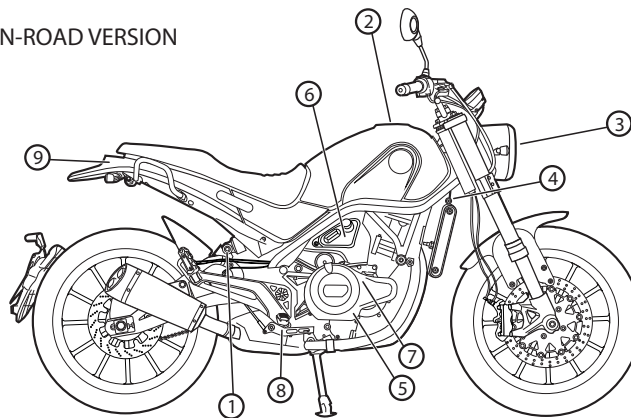

OFF-ROAD VERSION

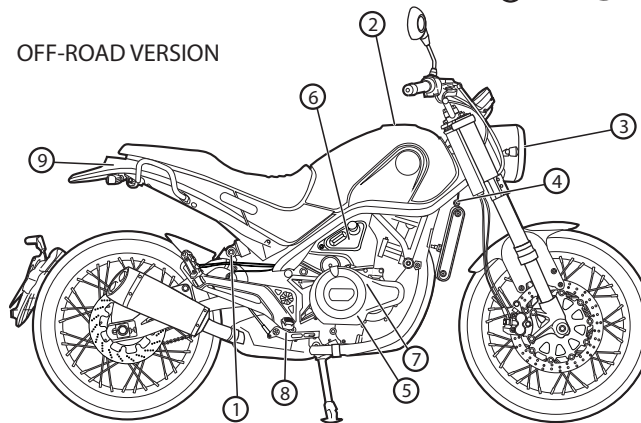

Description

Controls and instruments

1. Clutch lever
2. Left handlebar switches
3. Multi-function meter unit
4. Right handlebar switches
5. Throttle grip
6. Front brake lever
7. Front brake fluid reservoir
8. Ignition switch/steering lock
9. ABS switch



Key

The bike is supplied with 2 keys for:

- Opening the fuel cap
- Steering lock
- Ignition
- Opening the seat

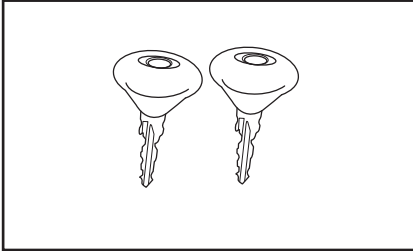

NOTICE

- **Do not submerge any key in water.**
- **Do not expose any key to excessively high temperatures.**
- **Do not place heavy items on any key.**
- **Do not grind any key or alter its shape.**
- **Do not disassemble the plastic part of any key.**
- **Always keep duplicate keys separately from the bike.**

Ignition switch/steering lock

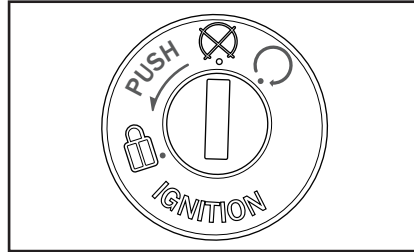

The ignition switch/steering lock controls the ignition and lighting systems, and is used to lock the steering. The various positions are described below.

○ (on)

All electrical circuits are supplied with power.

The meter lighting, taillight, license plate light and auxiliary lights come on, and the engine can be started. The key cannot be removed.

TIP



The headlights come on automatically when the engine is started and stay on until the key is turned to .

(off)

All electrical systems are off. The key can be removed.



WARNING

Never turn the key to  or  while the vehicle is moving. Otherwise the electrical systems will be switched off, which may result in loss of control or an accident.

(lock)

The steering is locked and all electrical systems are off. The key can be removed.

Instrument and control functions

To lock the steering:

- 1) Turn the handlebar completely to the left.
- 2) Insert the key in the ignition.
- 3) Turn the key anticlockwise, in the “” position to lock the steering.
- 4) Remove the key.

To unlock the steering:

- 1) Insert the key in the steering lock.
- 2) Turn the key clockwise.
- 3) Make sure the steering lock is not engaged before starting the engine and setting out.

TIP

To make it easier to engage the steering lock, move the handlebar slightly while turning the key.

TIP

After locking, try turning the handlebar slightly to make sure that the steering is actually locked.

Multi-function meter unit, Indicator lights, and warning lights

1. Tachometer
2. "ADJUST" button
3. "SELECT" button
4. Coolant temperature
5. Engine trouble warning light
6. Left turn signal indicator light
7. High beam indicator light
8. Neutral indicator light
9. Oil pressure warning light
10. Digital Clock
11. Transmission gear display
12. Total/partial mileage counter
13. Reserve fuel indicator
14. Speedometer
15. Fuel gauge
16. Anti-lock Brake System (ABS) warning light
17. Right turn signal indicator light
18. Thermometer

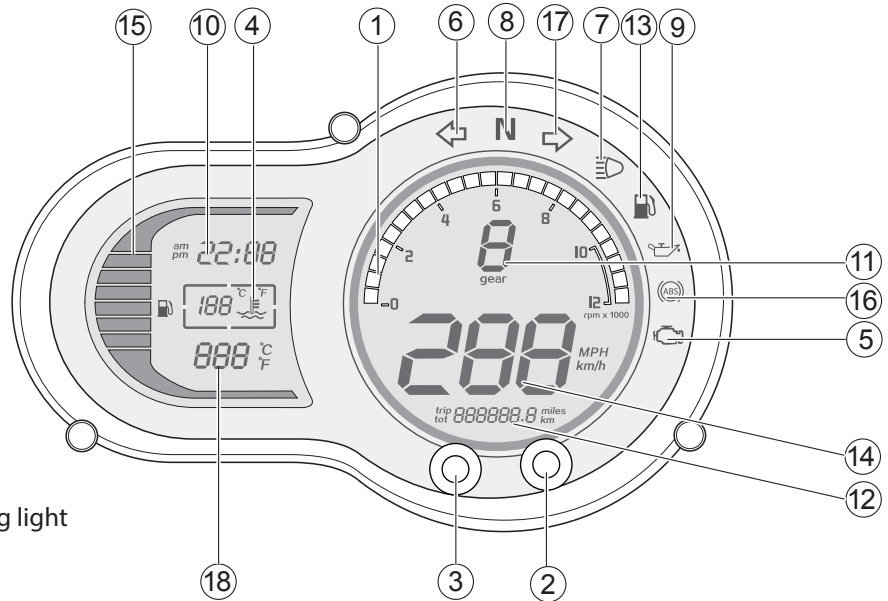

Instrument and control functions

Turn signal indicator lights “” and “”

Each indicator light will flash when its corresponding turn signal lights are flashing.

Neutral indicator light “N”

This indicator light comes on when the transmission is in the neutral position.

High beam indicator light “”

This indicator light comes on when the high beam of the headlight is switched on.

Oil pressure warning light “”

This light switches on when the engine oil pressure is low.

It is possible to check the electrical circuit for the light by turning the key to “”.

Once the engine is running, the light should switch off.

If the light does not switch on when the key is turned to “” or if the light stays on, get the electrical circuit checked by an authorized Benelli dealer.

TIP

- Even if the oil level is sufficient, the warning light may flicker when riding on a slope or during sudden acceleration or deceleration, but this is not a malfunction.
- If a problem is detected in the oil level detection circuit, the oil level warning light will flash repeatedly. If this occurs, have a Benelli dealer check the vehicle.

Engine trouble warning light “”

This warning light comes on if a problem is detected in the engine or other vehicle control system. If this occurs, have a Benelli dealer check the on-board diagnostic system.

The electrical circuit of the warning light can be checked by turning the key to “”:

The warning light should come on for a few seconds, and then go off.

If the warning light does not come on initially when the key is turned to “”; or if the warning light remains on, have a Benelli dealer check the vehicle.

Tachometer

The tachometer shows the engine revolutions per minute so that the rider can keep it within the ideal power range.

Coolant temperature

This shows the temperature of the coolant.

The coolant temperature varies with changes in the weather and engine load. If the “warning lamp” flashes, stop the vehicle then stop the engine and let it cool.



WARNING

Do not continue to operate the engine if it is overheating.

Digital clock

Shows the time in hours and minutes.

Digital clock setting

Push and hold the menu switch "SELECT" for 3 seconds to enter the setting mode "TOTAL KM".

Press and hold down the "SELECT" button for 3 seconds until the reading begins to flash.

Adjust the hour by pressing the "ADJUST" button.

Press the "SELECT" button to pass on to adjust the minutes. Adjust the minutes by pressing the "ADJUST" button.

Press the "SELECT" button again to quit.

Fuel gauge

The digital fuel gauge shows the capacity of the fuel tank. As the fuel level drops, the lines on the gauge will become closer and closer to the "E" reserve area.

As soon as the final line starts to flash, there is an approximately 1.3 liters (0.34 gal) of fuel remaining.

Speedometer

Push and hold the menu switch "SELECT" for 3 seconds to enter the setting mode "TOTAL KM".

Speedometers Indicates the vehicle's speed in km/h or mph. To pass from one to the other, press the "ADJUST" button.

Total/partial mileage counter

The total mileage counter shows the total distance covered in miles.

Set in the mode instrumentation "TRIP A / TRIP B" with the "SELECT" button.

The partial mileage counter (TRIP A/TRIP B) shows the distance covered since the last reset in miles.

The partial mileage counter can be used to estimate the possible distance to cover with a full tank of fuel. This information may make it possible to schedule future fueling stops.

RESET/SELECT buttons

Buttons to set vehicle data.

Press the "SELECT" button to see the partial or total mileage.

When viewing partial mileage (TRIP A/ TRIP B), it is possible to reset them by holding down the "ADJUST" button for 3 seconds.

Transmission gear display

The transmission gear display shows the selected gear.

This model is equipped with 6 gears.

Anti-lock Brake System (ABS) warning light

1. **ABS error:** whenever any fault is detected and saved, the ABS diagnostic light is on.

The ABS diagnostic light will turn off with the next SHUTDOWN/ IGNITION of the instrument panel or when the vehicle exceeds the speed of about 5 km/h.

2. **Disabled ABS mode:** the ABS diagnostic light will flash once for about 1.30 seconds (short flashing).

3. By keeping the ABS button pressed for a time of 3/30 seconds, the ABS diagnostic light will flash once for about 0.30 seconds (short flashing).

4. **ABS activated:** When the instrument panel is on, the ABS diagnostic light will be on until the vehicle reaches the speed of about 5 km/h. Once having exceeded this speed, the diagnostic light will turn off.

Instrument and control functions



WARNING

Usually the ABS diagnostic light stays on when the instrument panel is switched on and turns off when the vehicle speed is above 5 km/h.

If the ABS diagnostic light shows one of the following symptoms, one or more faults may have occurred on the ABS system.

- The ABS diagnostic light does not go on when the instrument panel is switched on.
- The ABS diagnostic light will stay on even when the vehicle exceeds the speed of about 5 km/h.

In either event, take the motorcycle to an authorized Benelli service center.

It is important to point out the fact that the ABS is not active when the light is on, but the braking system will continue working as a normal system not equipped with ABS.

In this situation, hard braking may lock the wheels, causing slip and loss of stability of the motorcycle.

Reserve fuel indicator

Comes on when approximately 1.3 litres (0.34 gal) of fuel are left; in this case, fill up the tank as soon as possible.

Thermometer

Displays the ambient temperature in centigrade degrees (°C) or Fahrenheit (°F). The range is between -30 and +50 (°C) or -22 and +122 (°F).

TIP

When a °F value greater than 99°F is displayed, the hundreds are not indicated.

Handlebar switches

Left

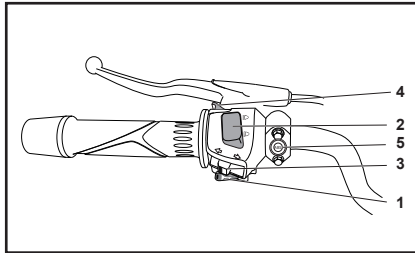

1. Horn switch "🔊"
2. Dimmer/switch "☰/☷"
3. Turn signal switch "↔"
4. Passing button
5. ABS switch (Ⓜ)

Right

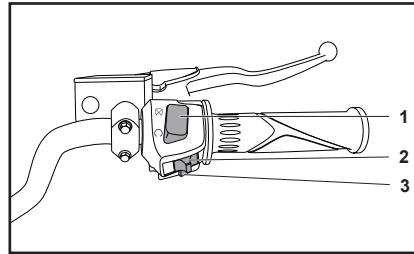

1. Run/Start switch "⊗/⊙"
2. Hazard switch "⚠"
3. Electric ignition button

Horn switch "🔊"

Press this switch to sound the horn.

Dimmer/switch "☰/☷"

Set this switch to "☷" for the high beam and to "☰" for the low beam.

Turn signal switch "↔"

To signal a right-hand turn, push this switch to "↗". To signal a left-hand turn, push this switch to "↖". When released, the switch returns to the center position. To cancel the turn signal lights, push the switch in after it has returned to the center position.

Passing button

Press this button (daytime) to temporarily enable the high beam light.

Run/Start switch "⊗/⊙"

To crank the engine with the starter, set this switch to "⊙", see page 5-1 for starting instructions prior to starting the engine.

Set this switch to "⊗" to stop the engine in case of an emergency, such as when the vehicle overturns or when the throttle cable is stuck.

Hazard switch "⚠"

With the ignition key set to "⊙" use this switch to switch on the emergency lights (simultaneous flashing of all of the direction indicators).

The emergency lights are used in case of emergency, to advise the other road users that your vehicle is about to stop in dangerous traffic areas.



WARNING

Do not use the emergency lights when the engine is off; this is to stop the battery from draining quickly.

Instrument and control functions

Electric ignition button

Press this button to start the engine with the starter device.

ABS button

Do not try to adjust the ABS settings while the motorcycle is running. The ABS settings are not enabled when the vehicle speed is above 5 km/h.

Disabling ABS

Make sure the motorcycle is stationary and in neutral. Keep the ABS button pressed for 3-5 seconds, the light will switch from steady to flashing for about 1.30 seconds (short flashing).

At this stage, the ABS system will be deactivated and the braking system will continue working as a normal system not equipped with ABS.

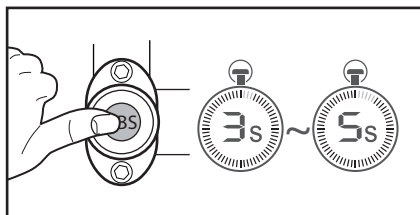

Enabling ABS:

Make sure the motorcycle is stationary and in neutral. Keep the ABS button pressed for 3-5 seconds, the light will switch from steady to flashing for about 1.30 seconds (short flashing). Another way to enable the ABS system is to switch it off and then on again.

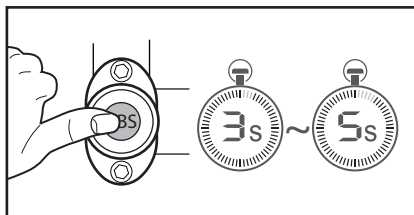

A: the procedure will be ignored by the system if the ABS button was pressed for a time ranging from 5 to 30 seconds. The ABS will keep the current settings.

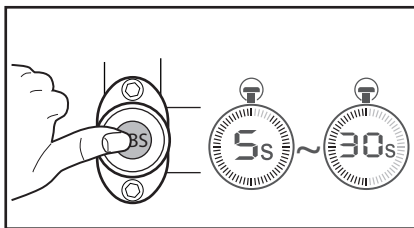

B: The ABS will be active again from any other previous setting when the button is pressed for a time longer than 30 secs.

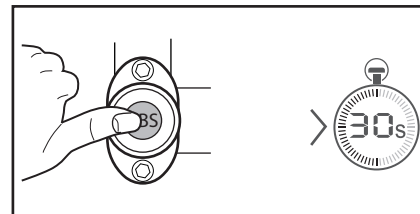

Clutch lever

The clutch lever is located on the left side of the handlebar.

To disengage the clutch, pull the lever toward the handlebar grip. To engage the clutch, release the lever. The lever should be pulled rapidly and released slowly for smooth clutch operation.

The clutch lever is equipped with a clutch switch, which is part of the ignition circuit cut-off system. (See page 3-17).

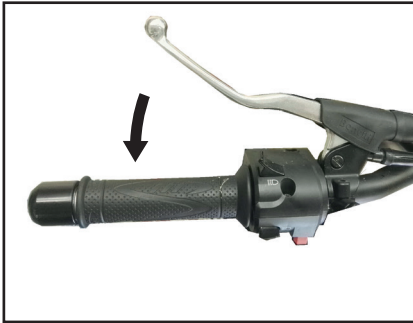

Shift lever

The shift lever is located on the left side of the motorcycle and is used in combination with the clutch lever when shifting the gears of the 6-speed constant-mesh transmission equipped on this motorcycle.

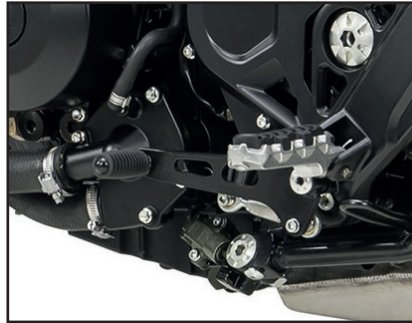

TIP

Always change down one gear at a time and at the correct speed to avoid engine over rev and skidding of the rear wheel.

Brake lever

The brake lever is located on the right side of the handlebar. To apply the front brake, pull the lever toward the throttle grip. The brake lever has a position adjustment knob.

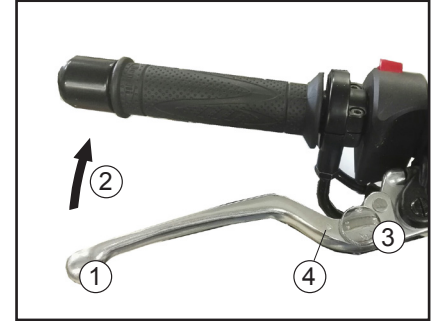

1. Brake lever
2. Distance between brake lever and throttle grip
3. Brake lever position adjusting knob
4. "▲" mark

To adjust the distance between the brake lever and the throttle grip, turn the knob clockwise or anticlockwise; anticlockwise will move the lever closer, while clockwise will move it further away. Make sure that the correct adjustment, set from

Instrument and control functions

the adjustment gauge is in line with the brake lever reference "▲".

Brake pedal

The brake pedal is located on the right side of the motorcycle. To apply the rear brake, press down on the brake pedal.

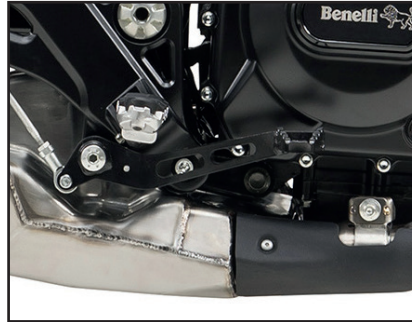

ABS

The anti-lock system (ABS) is designed to prevent locking of wheels during braking. The ABS controls the braking power automatically and intermittently, allowing the wheels to gain grip on the road and increasing the vehicle stability.

- For more efficiency, use the front brake and the rear one at the same time and in the same manner, as on a vehicle without ABS.
- The ABS cannot compensate for road harsh conditions or an improper use of the braking system. During braking, act with the same care as operating a vehicle without ABS.
- The anti-lock system (ABS) helps to prevent locking of the wheels during braking with the motorcycle riding in a straight line.
- During cornering, it is advisable to use both brakes in a soft manner and to reduce the speed gradually. As on a traditional braking system, hard and excessive braking may cause a sudden lock of the wheels and motorcycle loss of control.
- During braking, the ABS will not prevent the rear wheel from raising from the ground.
- The ABS control unit always uses the vehicle speed data and wheel rotation speed. Do not use non-appro-

ved tires to avoid ABS malfunction and cause an extension of the braking distance.

WARNING

The ABS cannot protect the rider from every danger and it is necessary to drive the vehicle in a responsible way. It is important to know the ABS operation and its limits. It is the responsibility of the rider to drive in a responsible way, according to the type of asphalt, road and traffic conditions.

The ABS is monitored by an ECU, which will revert the system to conventional braking if a malfunction occurs.

TIP

- The ABS light may go on during extreme driving conditions or in situations that lead to a different rotation speed of the front and rear wheels. In this situation, it is necessary to bring the ignition key to the "OFF" position, and then back to the "ON" position. After this procedure, the ABS light will turn off.
- If the light will still stay on even after

having reached or exceeded the speed of about 5 km/h, contact an authorized Benelli service center for inspection/repair.

- When the ABS is working, a pulsation may be felt on the brake lever or the brake pedal.
- The ABS is not active when the speed is below or equal to about 5 km/h.
- The ABS does not work in case of low battery.

NOTICE

Be careful not to damage the wheel sensor or wheel sensor rotor; otherwise, improper performance of the ABS will result.

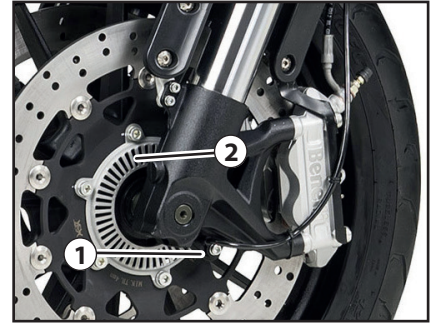

1. Front wheel sensor
2. Front sensor rotor

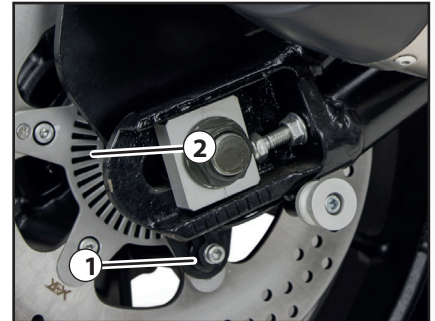

1. Rear wheel sensor
2. Rear sensor rotor

Instrument and control functions

Fuel tank cap



To open the fuel tank cap

Open the fuel tank cap lock cover, insert the key into the lock, and then turn it 1/4 turn clockwise. The lock opens and it is possible to raise the fuel cap.

To close the fuel tank cap

1) Insert the key in the lock.
2) Turn the key back to its original position by turning it anticlockwise and then remove it.



WARNING

Make sure that the fuel tank cap is properly closed after filling the tank. Leaking fuel is a fire hazard.

Fuel

Make sure there is sufficient gasoline in the tank.



WARNING

Gasoline and gasoline vapors are extremely flammable. To avoid fires and explosions and to reduce the risk of injury when refueling, follow these instructions.

- Before refueling, turn off the engine and be sure that no one is sitting on the vehicle. Never refuel while smoking, or while in the vicinity of sparks, open flames, or other sources of ignition such as the pilot lights of water heaters and clothes dryers.
- Do not overfill the fuel tank. When refueling, be sure to insert the pump nozzle into the fuel tank filler hole. Stop filling when the fuel reaches the bottom of the filler tube. Because fuel expands when it heats up, heat from the engine or the sun can cause fuel to spill out of the fuel tank.

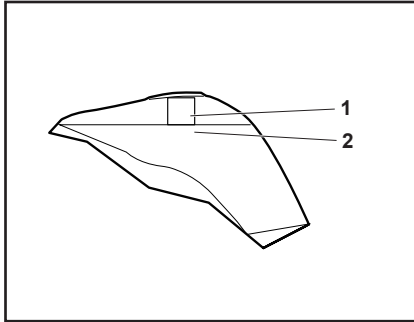

1. Fuel tank filler tube
2. Maximum fuel level

- Wipe up any spilled fuel immediately.

NOTICE

Immediately wipe off spilled fuel with a clean, dry, soft cloth, since fuel may deteriorate painted surfaces or plastic parts.

- Be sure to securely close the fuel tank cap.



WARNING

Gasoline is poisonous and can cause injury or death. Handle gasoline with care. Never siphon gasoline by mouth. If you should swallow some gasoline or inhale a lot of gasoline vapor, or get some gasoline in your eyes, see your doctor immediately.

If gasoline spills on your skin, wash with soap and water. If gasoline spills on your clothing, change your clothes.

Recommended fuel:

Premium unleaded gasoline 91 octane

Fuel tank capacity:

12.7 L (3.35 gal)

Fuel reserve amount:

1.3 L (0.34 gal)

NOTICE

Use only unleaded gasoline. The use of leaded gasoline will cause severe damage to internal engine parts, such as the valves and piston rings, as well as to the exhaust system.

Your Benelli engine has been designed to use premium unleaded gasoline with a research octane number of 91 or higher. If knocking (or pinging) occurs, use a gasoline of a different brand. Use of unleaded fuel will extend spark plug life and reduce maintenance costs.

Instrument and control functions

Catalytic converter

This model is equipped with a catalytic converter in the exhaust system.

WARNING

The exhaust system is hot after operation.

To prevent a fire hazard or burns:

- Do not park the vehicle near possible fire hazards such as grass or other materials that easily burn.
- Park the vehicle in a place where pedestrians or children are not likely to touch the hot exhaust system.
- Make sure that the exhaust system has cooled down before doing any maintenance work.
- Do not allow the engine to idle more than a few minutes. Long idling can cause a build-up of heat.

NOTICE

Use only unleaded gasoline. The use of leaded gasoline will cause unreparable damage to the catalytic converter.

3 - 14

Seat

To remove the seat

1. Insert the key and turn it counter clockwise to open the saddle.



2. Lift at the rear to remove the seat.

To install the seat

1. Insert the seat (front tab first) and press down gently on the back to close it.

Adjusting the headlight beams

The headlight beam adjusting screw is used to raise or lower the height of the headlight beams. It may be necessary to adjust the headlight beams to increase visibility and help prevent blinding oncoming drivers when carrying more or less load than usual.

Obey local laws and regulations when adjusting the headlights.

To raise the headlight beams, turn the screw in direction (A).

To lower the headlight beams, turn the screw in direction (B).

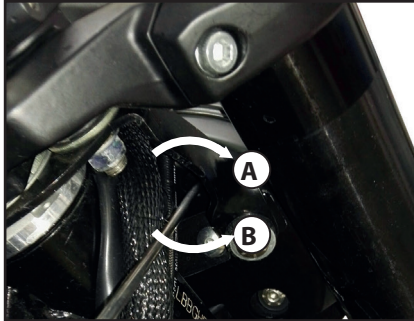

Adjusting the shock absorber assembly

Adjustment of the hydraulic compression dampening.

It is possible to adjust the hydraulic compression dampening using the adjustment knob. Turn it in direction "2" to increase the dampening; turn it in direction "3" to reduce it.

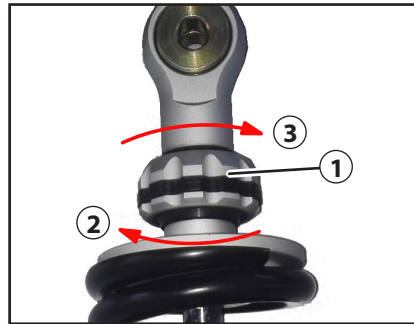

1. Adjustment knob.
2. Increase compression dampening.
3. Decrease compression dampening.

NOTICE

To avoid damaging the mechanism, do not try turning over the maximum or minimum setting. Always have the shock absorber adjusted by a Benelli dealership.

WARNING

Read and understand the following information before handling the shock absorber assembly.

- Do not tamper with or attempt to open the cylinder assembly.
- Do not subject the shock absorber assembly to an open flame or other high heat source. This may cause the unit to explode due to excessive gas pressure.
- Do not deform or damage the cylinder in any way. Cylinder damage will result in poor damping performance.
- Do not dispose of a damaged or worn-out shock absorber assembly yourself. Take the shock absorber assembly to a Benelli dealer for any service.

Instrument and control functions

Adjustment spring preload

The preload on the external spring of the shock absorber can be adjusted using the adjusting knob (1), on the right side of the frame, and following the values shown on the knob itself.

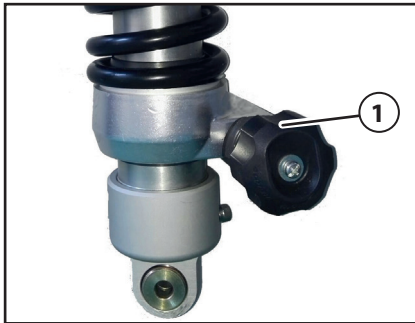

Adjusting the front fork

NOTICE

To avoid damaging the mechanism, do not try turning over the maximum or minimum setting.

Rebound damping force

To increase the rebound damping force and thereby harden the rebound damping, turn the adjusting screw in direction (A).

To decrease the rebound damping force and thereby soften the rebound damping, turn the adjusting screw in direction (B).

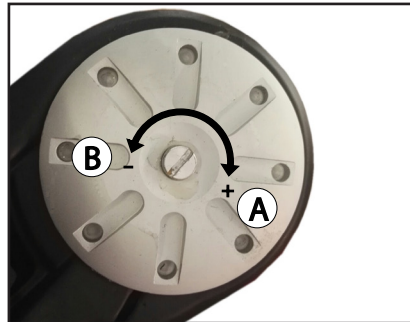

LEONCINO	
Front Suspension	Standard
Rebound Dampening	-2 turns from all close position
LEONCINO TRAIL	
Front Suspension	Without Setting

Sidestand

The sidestand is located on the left side of the frame. Raise the sidestand or lower it with your foot while holding the vehicle upright.

TIP

The built-in sidestand switch is part of the ignition circuit cut-off system, which cuts the ignition in certain situations. (See the following section for an explanation of the ignition circuit cut-off system.)



WARNING

The vehicle must not be ridden with the sidestand down, or if the sidestand cannot be properly moved up (or does not stay up), otherwise the sidestand could contact the ground and distract the operator, resulting in a possible loss of control.

Benelli's ignition circuit cut-off system has been designed to assist the operator in fulfilling the responsibility of raising the sidestand before starting off. Therefore, check this system regularly and have a Benelli dealer repair it if it does not function properly.

Ignition circuit cut-off system

The ignition circuit cut-off system (comprising the sidestand switch, clutch switch and neutral switch) has the following functions.

- It prevents starting when the transmission is in gear and the sidestand is up, but the clutch lever is not pulled in.
- It prevents starting when the transmission is in gear and the clutch lever is pulled in, but the sidestand is still down.
- It cuts the running engine when the transmission is in gear and the sidestand is moved down.

Periodically check the operation of the ignition circuit cut-off system according to the following procedure.

Instrument and control functions

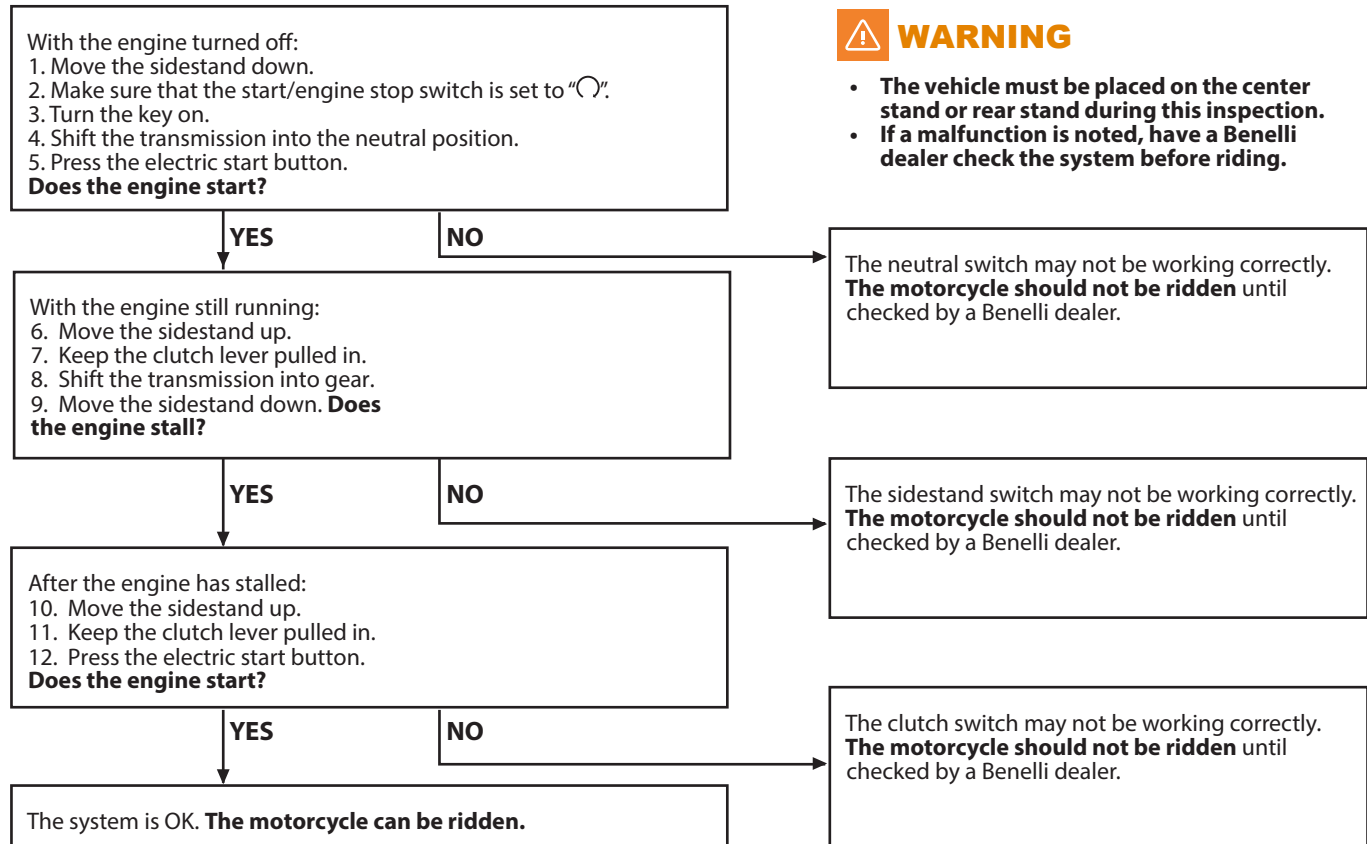

NOTES

.....

.....

.....

.....

.....

.....

.....

.....

.....

For your safety – pre-operation checks

Inspect your vehicle each time you use it to make sure the vehicle is in safe operating condition. Always follow the inspection and maintenance procedures and schedules described in the Owner's Manual.



Failure to inspect or maintain the vehicle properly increases the possibility of an accident or equipment damage. Do not operate the vehicle if you find any problems. If a problem cannot be corrected by the procedures provided in this manual, have the vehicle inspected by a Benelli dealer.

Before using this vehicle, check the following points:

ITEM	CHECKS
Fuel	<ul style="list-style-type: none">• Check the fuel level in the fuel tank.• Refuel if necessary.• Check fuel lines for leakage.
Engine oil	<ul style="list-style-type: none">• Check the oil level in the engine.• If necessary, add recommended oil to specified level.• Check vehicle for oil leakage.
Coolant	<ul style="list-style-type: none">• Check the coolant level in the reservoir.• If necessary, add the recommended coolant to the specified level.• Check the cooling system for leakage.
Front brake	<ul style="list-style-type: none">• Check operation.• If soft or spongy, have a Benelli dealer bleed the hydraulic system.• Check the brake pads for wear.• Replace them if necessary.• Check the fluid level in the reservoir.• If necessary, add the specified brake fluid to the specified level.• Check the hydraulic system for leakage.

For your safety – pre-operation checks

ITEM	CHECKS
Rear brake	<ul style="list-style-type: none">• Check operation.• If soft or spongy, have a Benelli dealer bleed the hydraulic system.• Check the brake pads for wear.• Replace them if necessary.• Check the fluid level in the reservoir.• If necessary, add the specified brake fluid to the specified level.• Check the hydraulic system for leakage.
Clutch	<ul style="list-style-type: none">• Check operation.• Lubricate the cable if necessary.• Check the lever free play.• Adjust it if necessary.
Throttle grip	<ul style="list-style-type: none">• Make sure that the operation is smooth.• Check the throttle grip free play.• If necessary, have a Benelli dealer adjust the throttle grip free play and lubricate the cable and grip housing.
Control cables	<ul style="list-style-type: none">• Make sure that operation is smooth.• Lubricate if necessary.
Drive chain	<ul style="list-style-type: none">• Check the chain slack.• Adjust it if necessary.• Check the chain condition.• Lubricate it if necessary.
Wheels and tires	<ul style="list-style-type: none">• Check for damage.• Check tire condition and tread depth.• Check air pressures.• Correct if necessary.
Brake and shift pedals	<ul style="list-style-type: none">• Make sure that the operation is smooth.• Lubricate pedal pivoting points if necessary.

For your safety – pre-operation checks

ITEM	CHECKS
Brake and clutch levers	<ul style="list-style-type: none">• Make sure that the operation is smooth.• Lubricate the lever pivoting points if necessary.
Sidestand	<ul style="list-style-type: none">• Make sure that operation is smooth.• Lubricate pivots if necessary.
Chassis fasteners	<ul style="list-style-type: none">• Make sure that all nuts, bolts, and fasteners are properly tightened.• Tighten if necessary.
Instruments, lights, signals and switches	<ul style="list-style-type: none">• Check operation.• Correct if necessary.
Sidestand switch	<ul style="list-style-type: none">• Check the operation of ignition circuit cut-off system.• If the system is not working correctly, have a Benelli dealer check the vehicle.

Read the Owner's Manual carefully to become familiar with all of the controls. If there is a control or function you do not understand, ask your Benelli dealer.



WARNING

Failure to familiarize yourself with the controls can lead to loss of control, which could cause an accident or injury

TIP

This model is equipped with:

- a lean angle sensor to stop the engine in case of a turnover.

Starting the engine

In order for the ignition circuit cut-off system to enable starting, one of the following conditions must be met:

- The transmission is in the neutral position.
- The transmission is in gear with the clutch lever pulled and the sidestand up. See page 3-17 for more information.

1. Turn the key to "⊖".

The following warning lights and indicator light should come on for a few seconds, then go off.

- Oil level warning light
- Neutral indicator light (when in gear)
- The ABS warning light

The ABS warning light should come on when the key is turned to "⊖", and then go off after traveling at a speed of 5 km/h (3 mi/h) or higher.

NOTICE

If the ABS warning light does not come on and then go off as explained above, see page 3-5 for the warning light circuit check.

2. Shift the transmission into the neutral position. The neutral indicator light should come on. If not, ask a Benelli dealer to check the electrical circuit.

3. Start the engine by sliding the switch toward "⊖".

If the engine fails to start, release the start/engine stop switch, wait a few seconds, and then try again. Each starting attempt should be as short as possible to preserve the battery. Do not crank the engine longer than 10 seconds on any one attempt.

NOTICE

For maximum engine life, never accelerate hard when the engine is cold!

Operation and important riding points

Shifting

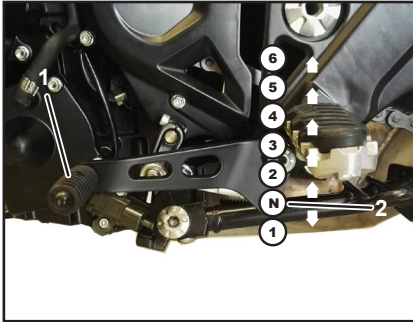

1. Shifter lever
2. Neutral position

Shifting gears lets you control the amount of engine power available for starting off, accelerating, climbing hills, etc. The gear positions are shown in the illustration above.

TIP

To shift the transmission into the neutral position, press the shift pedal down repeatedly until it reaches the end of its travel, and then slightly raise it.

NOTICE

- **Even with the transmission in the neutral position, do not coast for long periods of time with the engine off, and do not tow the motorcycle for long distances. The transmission is properly lubricated only when the engine is running. Inadequate lubrication may damage the transmission.**
- **Always use the clutch while changing gears to avoid damaging the engine, transmission, and drive train, which are not designed to withstand the shock of forced shifting.**

Tips for reducing fuel consumption

Fuel consumption depends largely on your riding style. Consider the following tips to reduce fuel consumption:

- Shift up swiftly, and avoid high engine speeds during acceleration.
- Do not rev the engine while shifting down, and avoid high engine speeds with no load on the engine.
- Turn the engine off instead of letting it idle for an extended length of time (e.g., in traffic jams, at traffic lights or at railroad crossings).

Engine break-in

There is never a more important period in the life of your engine than the period between 0 and 1600 km (1000 mi). For this reason, you should read the following material carefully.

Since the engine is brand new, do not put an excessive load on it for the first 1600 km (1000 mi). The various parts in the engine wear and polish themselves to the correct operating clearances.

During this period, prolonged full-throttle operation or any condition that might result in engine overheating must be avoided.

0–1000 km (621 mi)

Avoid prolonged operation above 5600 r/min.

NOTICE

After 1000 km (621 mi) of operation, the engine oil must be changed and the oil filter cartridge or element replaced.

1000–1600 km (621-1000 mi)

Avoid prolonged operation above 6800 r/min.

1600 km (1000 mi) or more

The vehicle can now be operated normally.

NOTICE

- **Keep the engine speed out of the tachometer high-rpm zone.**
- **If any engine trouble should occur during the engine break-in period, immediately have a Benelli dealer check the vehicle.**

Parking

When parking, stop the engine, and then remove the key from the main switch.



WARNING

- **Since the engine and exhaust system can become very hot, park in a place where pedestrians or children are not likely to touch them and be burned.**
- **Do not park on a slope or on soft ground, otherwise the vehicle may overturn, increasing the risk of a fuel leak and fire.**
- **Do not park near grass or other flammable materials which might catch fire.**

Operation and important riding points

NOTES

.....

.....

.....

.....

.....

.....

.....

.....

.....

Periodic inspection, adjustment, and lubrication will keep your vehicle in the safest and most efficient condition possible. Safety is an obligation of the vehicle owner/operator. The most important points of vehicle inspection, adjustment, and lubrication are explained on the following pages.

The intervals given in the periodic maintenance charts should be simply considered as a general guide under normal riding conditions.

However, depending on the weather, terrain, geographical location, and individual use, the maintenance intervals may need to be shortened.

WARNING

Failure to properly maintain the vehicle or performing maintenance activities incorrectly may increase your risk of injury or death during service or while using the vehicle. If you are not familiar with vehicle service, have a Benelli dealer perform service for you.

WARNING

Turn off the engine when performing maintenance unless otherwise specified.

- **A running engine has moving parts that can catch on body parts or clothing and electrical parts that can cause shocks or fires.**
- **Running the engine while servicing can lead to eye injury, burns, fire, or carbon monoxide poisoning – possibly leading to death. See page 1-2 for more information about carbon monoxide.**

Emission controls not only function to ensure cleaner air, but are also vital to proper engine operation and maximum performance.

In the following periodic maintenance charts, the services related to emissions control are grouped separately.

These services require specialized data, knowledge, and equipment.

Maintenance, replacement, or repair of the emission control devices and systems may be performed by any repair establishment or individual that is certified (if applicable). Benelli dealers are trained and equipped to perform these particular services.

WARNING

Brake discs, calipers, drums, and linings can become very hot during use. To avoid possible burns, let brake components cool before touching them.

Periodic maintenance and adjustment

Owner's tool kit

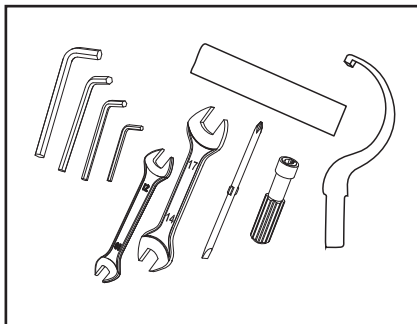

The bike is provided with a tool bag. The owner's tool kit is located under the passenger seat. The service information included in this manual and the tools provided in the owner's tool kit are intended to assist you in the performance of preventive maintenance and minor repairs. However, additional tools such as a torque wrench may be necessary to perform certain maintenance work correctly.

TIP

If you do not have the tools or experience required for a particular job, have a Benelli dealer perform it for you.

A list of workshops is available on our website www.benelli.com.

TIP

- The annual checks must be performed every year, except if a mileage-based maintenance is performed instead.
- At the 25.000 km (16.000 mi) coupon, perform maintenance operations with the same intervals indicated in the table. Items marked with an asterisk should be performed by a Benelli dealer as they require special tools, data and technical skills.
- The use of non-original replacement parts may accelerate motorbike wear and tear and cut short its life.
- Failure to perform recommended operations or the use of non-original parts may render the legal warranty null and void.
- The replacement and/or topping up of lubricants and fluids, must only be carried out with the recommended products.

TIP

AIR FILTER

The air filter needs to be replaced more often if the vehicle is used in particularly damp or dusty environments.

HYDRAULIC BRAKE MAINTENANCE

- Check brake fluid levels on a regular basis and top up as necessary.
- Every two years replace the internal components of the brake master cylinders and calipers, and change the brake fluid.
- Replace the brake hoses every four years and if cracked or damaged.

The following section shows all of the maintenance operations

	KEY
I	Inspection and adjustment, cleaning, lubrication or replacement, as needed
T	Tighten to the torque listed
R	Replacement
☑	Dealer

General maintenance and lubrication chart

No.	Part	Maintenance intervention or control	0 Km Pre-delivery	1.000 Km 621 mi service	7.000 Km 4.400 mi service	13.000 Km 8.000 mi service	19.000 Km 12.000 mi service	25.000 Km 16.000 mi service	Annual Inspection
1	Engine oil	Top up/Replacement	I	R	R	R	R	R	R
		Check	Every 500 km (300 mi)						
2	Oil Filter	Replacement	I	R	R	R	R	R	R
3	■ Fuel Filter	Check/Replacement			I	I	R	I	
4	■ Air Filter	Check/Replacement			I	R	I	R	
5	■ Coolant	Check/Top up/Replacement	I	I	I	R	I	I	I
		Replace	Every 2 years or 13.000 km (8.000 mi)						
6	■ Cooling system	Check the level of the coolant and make sure there are no leaks from the vehicle	I	I	I	I	I	I	I
7	■ Spark plugs	Check/Replacement			I	I	R	I	I
		Check the conditions, clean and restore the distance between electrodes							
8	■ Transmission Chain	Check chain tension Make sure that the rear wheel is correctly aligned Clean and lubricate		I	I	I	I	I	I
		Every 500 km (300 mi) and after every wash or if the motorcycle has been used in the rain.							
9	■ Sprockets	Check/Lubricate		I	I	I	I	I	I
		Replace every time the chain is replaced							
10	■ Pinion/Retaining washer	Check/Replacement		I	I	I	I	I	I
		Replace every time the chain is replaced							
11	■ Fuel circuit hoses	Check for faults/leaks			I	I	I	R	
		In any case, replace every 3 years							

Periodic maintenance and adjustment

No.	Part	Maintenance intervention or control	0 Km Pre-delivery	1.000 Km 621 mi service	7.000 Km 4.400 mi service	13.000 Km 8.000 mi service	19.000 Km 12.000 mi service	25.000 Km 16.000 mi service	Annual Inspection
12	■ Brake fluid / *clutch	Check/Top up/ Replace	I	I	I	I	I	R	I
In any case, replace every 2 years									
13	■ Front brake/ Rear brake	Check the operation of the fluid gauge and make sure there are no leaks from the vehicle	I	I	I	I	I	I	I
14	■ Brake pads	Check/Replacement		I	I	I	I	I	
Replace if worn to the limit									
15	■ Swingarm chain slider	Check/Replacement		I	I	I	I	I	
Replace if worn to the limit									
16	■ Clutch control	Check/Adjustment	I	I	I	I	I	I	
17	■ Throttle grip	Check operation and if necessary, adjust the throttle cable free play. Lubricate the throttle grip housing and cable	I	I	I	I	I	I	I
18	■ Throttle body	Check/Adjustment		I	I	I	I	I	
19	■ Valve clearance	Check operation/ Adjust clearance						I	
Every 25.000 km (16.000 mi)									

Periodic maintenance and adjustment

No.	Part	Maintenance intervention or control	0 Km Pre-delivery	1.000 Km 621 mi service	7.000 Km 4.400 mi service	13.000 Km 8.000 mi service	19.000 Km 12.000 mi service	25.000 Km 16.000 mi service	Annual Inspection
20	■ Timing chain	Check/Replacement						I	
			Every 25.000 km (16.000 mi)						
21	■ Timing chain guides	Check/Replacement						I	
			Every time the timing chain is changed or in any case 25.000 km (16.000 mi)						
22	■ Timing chain tensioner	Check/Replacement						R	
			Every time the timing chain is changed or in any case 25.000 km (16.000 mi)						
23	■ Steering ring nut and sleeve	Check/Adjustment	T	T	T	T	T	T	T
24	■ Steering bearings	Check				I	I	I	
25	■ Wheel bearings front / back	Check				I		I	
26	■ Fork bushings	Check/Replacement			I	I	I	I	
27	■ Swing arm	Check operation and make sure there is no excessive free play. Lubricate.			I	I	I	I	
28	■ Front suspension	Check operation and make sure there are no leaks	I	I	I	I	I	I	I

Periodic maintenance and adjustment

No.	Part	Maintenance intervention or control	0 Km Pre-delivery	1.000 Km 621 mi service	7.000 Km 4.400 mi service	13.000 Km 8.000 mi service	19.000 Km 12.000 mi service	25.000 Km 16.000 mi service	Annual Inspection
29	■ Rear suspension	Check/Adjust, and make sure there are no leaks.	I	I	I	I	I	I	I
30	■ Wheels	Make sure they are not off center or damaged.	I	I	I	I	I	I	
31	■ Tires	Check the depth of tread and make sure they are not damaged. Replace if necessary. Check inflation pressure. Correct if necessary	I	I	I	I	I	I	I
			Replace if worn to the limit						
32	■ Side stand	Check operation	I	I	I	I	I	I	I
33	■ Side stand Switch	Check operation	I	I	I	I	I	I	I
34	■ Wheel Dampers	Check operation				R		R	
			After at 13.000 km (8.000 mi), before every 12.000 km (7.500 mi)						
35	■ Instruments, lights, signals and switches	Check operation	I	I	I	I	I	I	I
36	■ Head light	Check operation	I	I	I	I	I	I	
		Adjustment	At every change in vehicle set-up						

Periodic maintenance and adjustment

No.	Part	Maintenance intervention or control	0 Km Pre-delivery	1.000 Km 621 mi service	7.000 Km 4.400 mi service	13.000 Km 8.000 mi service	19.000 Km 12.000 mi service	25.000 Km 16.000 mi service	Annual Inspection
37	■ Acoustic warning	Check operation	I	I	I	I	I	I	I
38	■ Instruments	Check operation	I	I	I	I	I	I	I
39	■ Battery Connections	Check operation	I	I	I	I	I	I	I
40	■ Electrical System	Check operation	I	I	I	I	I	I	I
41	■ Switch	Check operation	I	I	I	I	I	I	I
42	■ Electric fan	Check operation	I	I	I	I	I	I	I
43	■ Fuel injection	Check the idle speed and check synchronisation	I	I	I	I	I	I	I
44	■ ECU parameters	Check		I	I	I	I	I	I
45	■ Part fastening	Make sure all nuts, bolts and screws are sufficiently tightened	T	T	T	T	T	T	T
46	■ Oil sump screws	Check		T	T	T	T	T	

Periodic maintenance and adjustment

No.	Part	Maintenance intervention or control	0 Km Pre-delivery	1.000 Km 621 mi service	7.000 Km 4.400 mi service	13.000 Km 8.000 mi service	19.000 Km 12.000 mi service	25.000 Km 16.000 mi service	Annual Inspection
47	▣ Lid screws clutch	Check		T	T	T	T	T	
48	▣ Catalytic converter	Check for faults/leaks		I	I	I	I	I	
			No maintenance required. In case of malfunction replace.						
49	▣ Canister	Check for faults/leaks			I	I	I	I	
			No maintenance required. In case of malfunction replace.						
50	▣ Brake/clutch hoses	Check for faults/leaks	I	I	I	I	I	I	I
51	▣ Parts and wires subject to movement	Check/Replacement	I	I	I	I	I	I	I
			Replace if damaged.						
52	▣ Oil suction filter	Check/Replacement			I	I	I	I	
53	▣ Wheel spokes front/rear (TRAIL)	Check		I		I		I	

Checking the spark plugs

The spark plugs are important engine components, which should be checked periodically, preferably by a Benelli dealer. Since heat and deposits will cause any spark plug to slowly erode, they should be removed and checked in accordance with the periodic maintenance and lubrication chart. In addition, the condition of the spark plugs can reveal the condition of the engine.

The porcelain insulator around the center electrode of each spark plug should be a medium-to-light tan (the ideal color when the vehicle is ridden normally), and all spark plugs installed in the engine should have the same color.

If any spark plug shows a distinctly different color, the engine could be operating improperly.

Do not attempt to diagnose such problems yourself. Instead, have a Benelli dealer check the vehicle.

If a spark plug shows signs of electrode erosion and excessive carbon or other deposits, it should be replaced.

Specified spark plug:

NGK CR8E

Before installing a spark plug, the spark plug gap should be measured with a wire thickness gauge and, if necessary, adjusted to the following specification.

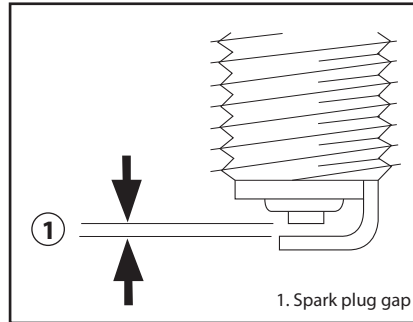

Spark plug gap:

0.7–0.8 mm

Clean the surface of the spark plug gasket and its mating surface, and then wipe off any grime from the spark plug threads.

Tightening torque:

15 N·m

TIP

If a torque wrench is not available when installing a spark plug, a good estimate of the correct torque is 1/4–1/2 turn past finger tight.

However, the spark plug should be tightened to the specified torque as soon as possible.

Periodic maintenance and adjustment

Canister



This model is equipped with a canister to prevent the discharging of fuel vapor into the atmosphere. Before operating this vehicle, make sure to check the following:

- Check each hose connection. Check
- each hose and the canister for cracks or damage. Replace if damaged.

Engine oil and oil filter cartridge

The engine oil level should be checked before each ride. In addition, the oil must be changed at the intervals specified in the periodic maintenance and lubrication chart.

To check the engine oil level

1. Place the vehicle on a flat surface and keep it upright. A slight tilt to the side can result in a false reading.
2. Start the engine, warm it up for several minutes, and then turn it off.
3. Wait a few minutes until the oil settles, and then check the oil level through the engine oil level check window located at the bottom-right side of the crankcase.

TIP

The engine oil should be between the minimum and maximum level marks.

4. If the engine oil is below the minimum level mark, add sufficient oil of the recommended type to raise it to the correct level.

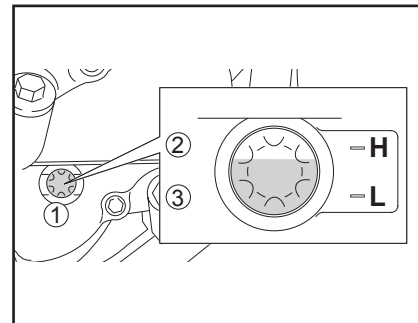

1. Engine oil level check window.
2. Maximum level mark.
3. Minimum level mark.

To change the engine oil (with or without oil filter cartridge replacement)

1. Place the vehicle on a flat surface and keep it upright.
2. Start the engine, warm it up for several minutes, and then turn it off.
3. Place an oil pan under the engine to collect the used oil.
4. Remove the engine oil filler cap, the engine oil drain bolt, and its gasket to drain the oil from the crankcase.

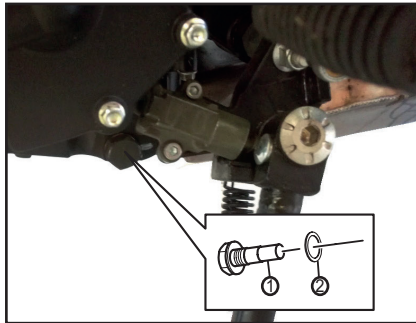

1. Engine oil drain bolt
2. Gasket

TIP

Skip steps 5–7 if the oil filter cartridge is not being replaced.

5. Remove the oil filter cartridge with an oil filter wrench.

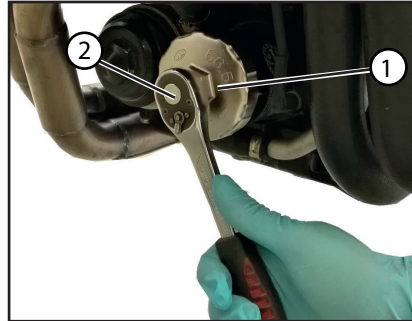

1. Oil filter wrench
2. Oil filter cartridge

TIP

An oil filter wrench is available at a Benelli dealer.

6. Apply a thin coat of clean engine oil to the O-ring of the new oil filter cartridge.

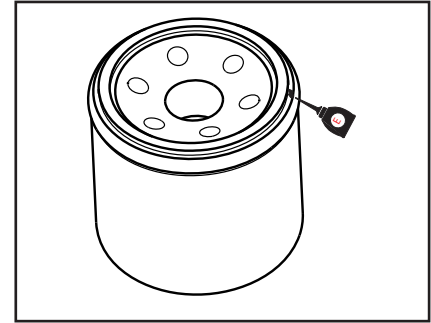

TIP

Make sure that the O-ring is properly seated.

7. Install the new oil filter cartridge with an oil filter wrench, and then tighten it to the specified torque with a torque wrench.

Tightening torque:

Oil filter cartridge:
18 N·m

Periodic maintenance and adjustment

8. Install the engine oil drain bolt and its new gasket, and then tighten the bolt to the specified torque.

Tightening torque:

Engine oil drain bolt:
22 N·m

9. Refill with the specified amount of the recommended engine oil, and then install and tighten the oil filler cap.

Oil quantity:

Oil change:
2.9 L

With oil filter removal:
3.0 L

TIP

Be sure to wipe off spilled oil on any parts after the engine and exhaust system have cooled down.

NOTICE

- **In order to prevent clutch slippage (since the engine oil also lubricates the clutch), do not mix any chemical additives. Do not use oils with a diesel specification of "CD" or oils of a higher quality than specified. In addition, do not use oils labeled "ENERGY CONSERVING II" or higher.**
- **Make sure that no foreign material enters the crankcase.**

10. Start the engine, and then let it idle for several minutes while checking it for oil leakage. If oil is leaking, immediately turn the engine off and check for the cause.

11. Turn the engine off, wait a few minutes until the oil settles, and then check the oil level and correct it if necessary.

TIP

After the engine is started, the engine oil level warning light should go off if the oil level is sufficient.

Coolant

The coolant level should be checked before each ride. In addition, the coolant must be changed at the intervals specified in the periodic maintenance and lubrication chart.

To check the coolant level

1. Place the vehicle on a flat surface and keep it upright.

TIP

- The coolant level must be checked on a cold engine since the level varies with engine temperature.
 - Make sure that the vehicle is positioned straight up when checking the coolant level. A slight tilt to the side can result in a false reading.
2. Check the coolant level in the coolant reservoir.

TIP

The coolant should be between the minimum and maximum level marks.

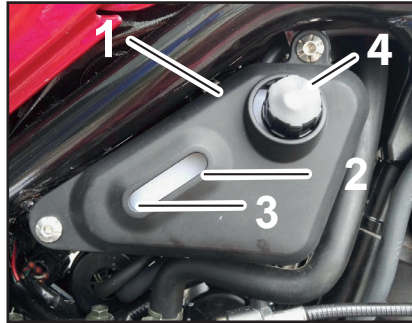

1. Coolant reservoir
2. Maximum level mark
3. Minimum level mark
4. Coolant reservoir cap

3. If the coolant is at or below the minimum level mark, remove the coolant reservoir cap.



WARNING

Only remove the coolant reservoir cap. Never attempt to remove the radiator cap when the engine is hot.

4. Add coolant or distilled water to raise the coolant to the maximum level mark, install the coolant reservoir cap.

NOTICE

If coolant is not available, use distilled water or soft tap water instead. Do not use hard water or salt water since it is harmful to the engine.
If water has been used instead of coolant, replace it with coolant as soon as possible, otherwise the cooling system will not be protected against frost and corrosion. If water has been added to the coolant, have a Benelli dealer check the antifreeze content of the coolant as soon as possible, otherwise the effectiveness of the coolant will be reduced.

Periodic maintenance and adjustment

To change the coolant

1. Place the vehicle on a flat surface and keep it upright.
2. Place a container under the engine to collect the used coolant.
3. Remove the radiator cap.



WARNING

Never attempt to remove the radiator cap when the engine is hot.

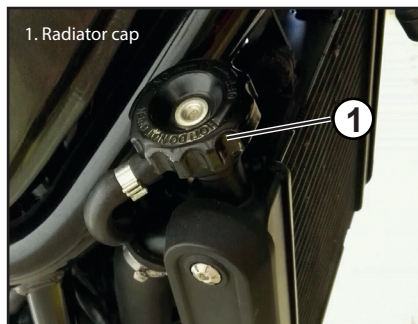

4. Remove the coolant drain bolt and its gasket to drain the cooling system.

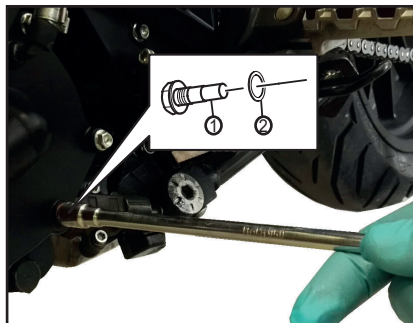

1. Coolant drain bolt
2. Gasket

5. After the coolant is completely drained, thoroughly flush the cooling system with clean tap water.
6. Install the coolant drain bolt and its new gasket, and then tighten the bolt to the specified torque.

Tightening torque:

Coolant drain bolt:
11 N·m

7. Pour the specified amount of the recommended coolant into the radiator and reservoir.

Antifreeze/water mixture ratio:

1:1

Recommended antifreeze:

High-quality ethylene glycol antifreeze containing corrosion inhibitors for aluminum engines

Coolant quantity:

Radiator (including all routes):

1.8 L

Coolant reservoir (up to the maximum level mark):

0.3 L

8. Install the coolant reservoir cap.
9. Install the radiator cap.
10. Start the engine, let it idle for several minutes, and then turn it off.
11. Remove the radiator cap to check the coolant level in the radiator. If necessary, add sufficient coolant until it reaches the top of the radiator, and then install the radiator cap.
12. Check the coolant level in the reservoir. If necessary, remove the coolant reservoir cap, add coolant to the maximum level mark, and then install the cap.

13. Start the engine, and then check the vehicle for coolant leakage. If coolant is leaking, have a Benelli dealer check the cooling system.

Air filter element

The air filter element must be replaced at the intervals specified in the periodic maintenance and lubrication chart. Have a Benelli dealer replace the air filter element.

Checking the engine idling speed

Check the engine idling speed and, if necessary, have it corrected by a Benelli dealer.

Engine idling speed:

1500-1600 r/min.

Periodic maintenance and adjustment

Checking the throttle grip free play

Measure the throttle grip free play as shown.



Throttle grip free play:

3.0 - 5.0 mm

Periodically check the throttle grip free play and, if necessary, have a Benelli dealer adjust it.

Valve clearance

The valve clearance changes with use, resulting in improper air-fuel mixture and/or engine noise. To prevent this from occurring, the valve clearance must be adjusted by a Benelli dealer at the intervals specified in the periodic maintenance and lubrication chart.

Tires

Tires are the only contact between the vehicle and the road. Safety in all conditions of riding depends on a relatively small area of road contact. Therefore, it is essential to maintain the tires in good condition at all times and replace them at the appropriate time with the specified tires.

Tire air pressure

The tire air pressure should be checked and, if necessary, adjusted before each ride.



WARNING

Operation of this vehicle with improper tire pressure may cause severe injury or death from loss of control.

- The tire air pressure must be checked and adjusted on cold tires (i.e., when the temperature of the tires equals the ambient temperature).
- The tire air pressure must be adjusted in accordance with the riding speed and with the total weight of rider, passenger, cargo, and accessories approved for this model.

Tire air pressure (measured on cold tires):

Front: 220 ± 10 kPa (32 psi)

Rear: 250 ± 10 kPa (36 psi)

Maximum load:

190 Kg (419 lbs)

* Total weight of rider, passenger,
cargo and accessories

WARNING

Never overload your vehicle. Operation of an overloaded vehicle could cause an accident.

Tire inspection

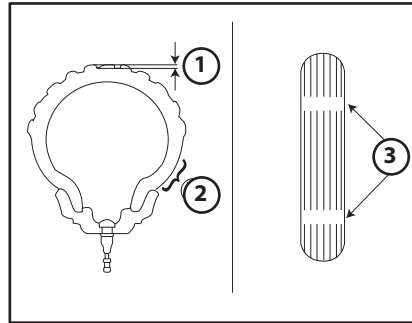

1. Tire tread depth
2. Side well
3. Tread wear indicator

The tires must be checked before each ride. If the center tread depth reaches the specified limit, if the tire has a nail or glass fragments in it, or if the sidewall is cracked, have a Benelli dealer replace the tire immediately.

Minimum tire tread depth (front and rear):

1.6 mm

TIP

The tire tread depth limits may differ from country to country. Always comply with the local regulations.

WARNING

- **Have a Benelli dealer replace excessively worn tires. Besides being illegal, operating the vehicle with excessively worn tires decreases riding stability and can lead to a loss of control.**
- **The replacement of all wheel and brake related parts, including the tires, should be left to a Benelli dealer, who has the necessary professional knowledge and experience to do so.**
- **Ride at moderate speeds after changing a tire since the tire surface must first be "broken in" for it to develop its optimal characteristics.**

Tires age, even if they have not been used or have only been used occasionally. Cracking of the tread and sidewall rubber, sometimes accompanied by carcass deformation, is evidence of ageing. Old

Periodic maintenance and adjustment

and aged tires shall be checked by tire specialists to ascertain their suitability for further use.

WARNING

- The front and rear tires should be of the same make and design, otherwise the handling characteristics of the motorcycle may be different, which could lead to an accident.
- Always make sure that the valve caps are securely installed to prevent air pressure leakage.

Front tire:

Size:

120/70ZR17 M/C (58W)

Rear tire:

Size:

160/60 ZR17 M/C (69W)

TRAIL Front tire:

Size:

110/80ZR19 M/C (59V)

TRAIL Rear tire:

Size:

150/70 ZR17 M/C (69V)

WARNING

- Use only the specified replacement tires. Other tires may run the danger of bursting at super high speeds.
- Brand-new tires can have a relatively poor grip on certain road surfaces until they have been “broken in”. Therefore, it is advisable before doing any high-speed riding to ride conservatively for approximately 100 km (60 mi) after installing a new tire.
- The tires must be warmed up before a high-speed run.
- Always adjust the tire air pressure according to the operating conditions.

Adjusting the clutch lever free play

Measure the clutch lever free play as shown.

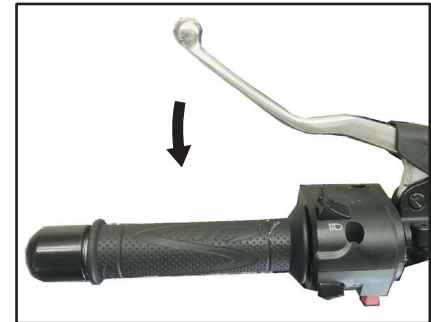

Clutch lever free play:

10.0 mm

Check the clutch lever backlash regularly and adjust as necessary.

- 1) Loosen the clutch ring nut and the clutch screw on the cable, at the same time.
- 2) To increase clutch lever free play, turn the clutch screw clockwise (seen from sitting on the bike). To reduce the clutch lever free play, turn

the clutch screw anticlockwise (seen from sitting on the bike).

3) After adjusting, tighten the clutch ring nut.

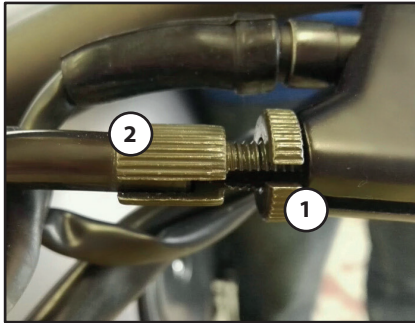

1. Clutch ring nut
2. Clutch screw

TIP

If the specified free play cannot be obtained as described above or if the clutch does not operate correctly, have a Benelli dealer check the internal clutch mechanism.

Checking the brake lever free play

There should be no free play at the brake lever end. If there is free play, have a Benelli dealer inspect the brake system.



Brake light switches

The brake light, which is activated by the brake pedal and brake lever, should come on just before braking takes effect. If necessary, have a Benelli dealer adjust the brake light switches.



WARNING

A soft or spongy feeling in the brake lever can indicate the presence of air in the hydraulic system. If there is air in the hydraulic system, have a Benelli dealer bleed the system before operating the vehicle. Air in the hydraulic system will diminish the braking performance, which may result in loss of control and an accident.

Periodic maintenance and adjustment

Checking the front and rear brake pads

The front and rear brake pads must be checked for wear at the intervals specified in the periodic maintenance and lubrication chart.

Front brake pads

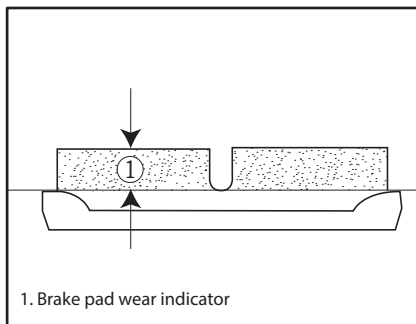

Each front brake pad is provided with wear indicators, which allows you to check the brake pad wear without having to disassemble the brake. To check the brake pad wear, check the position of the wear indicators while applying the brake. If a brake pad has worn to the point that a wear indicator almost touches the brake disc, have a Benelli dealer replace the brake pads as a set.

Rear brake pads

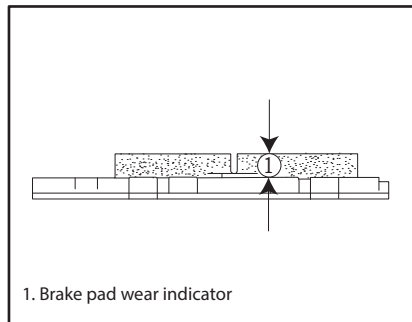

Each rear brake pad is provided with wear indicator grooves, which allow you to check the brake pad wear without having to disassemble the brake.

To check the brake pad wear, check the wear indicator grooves. If a brake pad has worn to the point that a wear indicator groove almost appears, have a Benelli dealer replace the brake pads as a set.

Checking the brake fluid level

Before riding, check that the brake fluid is above the minimum level mark. Check the brake fluid level with the top of the reservoir level. Replenish the brake fluid if necessary.

Front brake

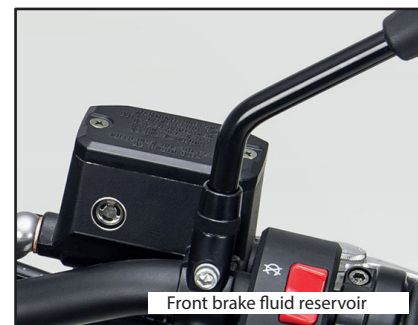

Rear brake

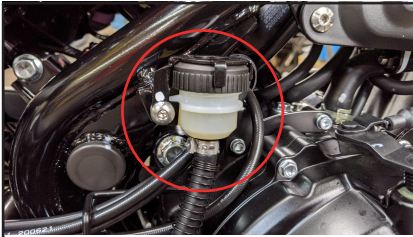

Rear brake fluid reservoir

Specified brake fluid:

DOT 4



WARNING

Improper maintenance can result in loss of braking ability.

Observe these precautions:

- **Insufficient brake fluid may allow air to enter the brake system, reducing braking performance.**
- **Clean the filler cap before removing. Use only DOT 4 brake fluid from a sealed container.**

- **Use only the specified brake fluid; otherwise, the rubber seals may deteriorate, causing leakage.**
- **Refill with the same type of brake fluid. Adding a brake fluid other than DOT 4 may result in a harmful chemical reaction.**
- **Be careful that water or dust does not enter the brake fluid reservoir when refilling. Water will significantly lower the boiling point of the fluid and may result in vapor lock, and dirt may clog the ABS hydraulic unit valves.**

NOTICE

Brake fluid may damage painted surfaces or plastic parts. Always clean up spilled fluid immediately.

As the brake pads wear, it is normal for the brake fluid level to gradually go down. A low brake fluid level may indicate worn brake pads and/or brake system leakage; therefore, be sure to check the brake pads for wear and the brake system for leakage. If the brake fluid level goes down suddenly, have a Benelli dealer check the cause before further riding.

Changing the brake fluid

Have a Benelli dealer change the brake fluid at the intervals specified in the periodic maintenance and lubrication chart.

Periodic maintenance and adjustment

Drive chain slack

The drive chain slack should be checked before each ride and adjusted if necessary.

To check the drive chain slack

1. After stopping the engine, place the vehicle on a rear stand on a horizontal surface and with the transmission in neutral.
2. Measure the drive chain slack as shown.

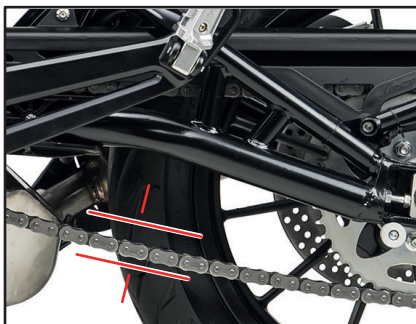

Drive chain slack:
25 - 35 mm

3. After rotating the rear wheel forward, check the free play slack at multiple locations, it must be the same throughout.
4. If the drive chain slack is incorrect,

adjust it as follows.

NOTICE

Using the motorcycle with the chain in poor condition and poorly adjusted may cause accidents.

If you notice any operating anomaly on the chain, such as excessive or suspicious noises, or excessive slack, go to an authorized Benelli dealer.

If you suspect that there is a serious malfunction with the chain, stop the bike immediately and call your nearest authorized Benelli dealer.

To adjust the drive chain slack

1. Loosen the wheel axle nut and lock nut on each side of the swingarm.
2. To tension the transmission chain, turn the tension adjustment bolt on each side of the swingarm (clockwise).
3. To loosen the transmission chain, turn the tension adjustment bolt on each side of the swingarm (anticlockwise) and push the rear wheel forwards.

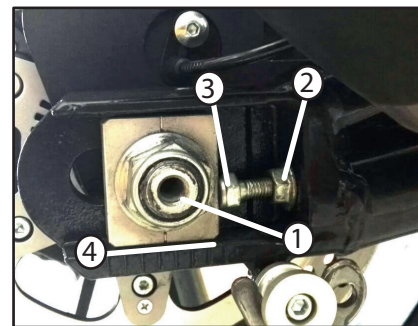

1. Axle nut
2. Locknut
3. Drive chain slack adjusting bolt
4. Measurement guide

NOTICE

Incorrect transmission chain tension will overload the engine and other vital parts of the motorcycle, and it may cause the chain to slip or break. To stop this from happening, keep the transmission chain tension within the specified limits. Make sure that the distance is the same for the left and right sides of the swingarm.

4. Tighten the wheel axle nut, keeping tension on the slides on the adjustment devices and lock nuts.

Tightening torques:

Axle nut:

100 N · m

Locknut:

20 N · m

Cleaning and lubricating the drive chain

The drive chain must be cleaned and lubricated at the intervals specified in the periodic maintenance and lubrication chart, otherwise it will quickly wear out, especially when riding in dusty or wet areas. Service the drive chain as follows.

NOTICE

The drive chain must be lubricated after washing the motorcycle, riding in the rain or riding in wet areas.

1. Clean the drive chain with a motorcycle chain cleaner and a small soft brush.

NOTICE

To prevent damaging the O-rings, do not clean the drive chain with steam cleaners, high-pressure washers or inappropriate solvents.

2. Wipe the drive chain dry.
3. Thoroughly lubricate the drive chain with a special O-ring chain lubricant.

NOTICE

Do not use engine oil or any other lubricants for the drive chain, as they may contain substances that could damage the O-rings.

Periodic maintenance and adjustment

Checking and lubricating the cables

The operation of all control cables and the condition of the cables should be checked before each ride, and the cables and cable ends should be lubricated if necessary. If a cable is damaged or does not move smoothly, have a Benelli dealer check or replace it.

WARNING

Damage to the outer housing of cables may result in internal rusting and cause interference with cable movement. Replace damaged cables as soon as possible to prevent unsafe conditions.

Checking and lubricating the throttle grip and cable

The operation of the throttle grip should be checked before each ride. In addition, the cable should be lubricated by a Benelli dealer at the intervals specified in the periodic maintenance chart.

The throttle cable is equipped with a rubber cover. Make sure that the cover is securely installed. Even though the cover is installed correctly, it does not completely protect the cable from water entry.

Therefore, use care not to pour water directly onto the cover or cable when washing the vehicle. If the cable or cover becomes dirty, wipe clean with a moist cloth.

Checking and lubricating the brake and shift pedals

The operation of the brake and shift levers should be checked before each ride, and the pedal pivots should be lubricated if necessary.

Brake pedal



Shift lever

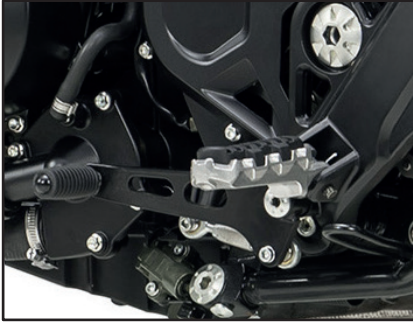

Recommended lubricant:
Lithium-soap-based grease

Checking and lubricating the brake and clutch levers

The operation of the brake and clutch levers should be checked before each ride, and the lever pivots should be lubricated if necessary.

Brake lever



Clutch lever



Recommended lubricant:

Brake lever:
Silicone grease
Clutch lever:
Silicone grease

Periodic maintenance and adjustment

Checking and lubricating the sidestand

The operation of the sidestand should be checked before each ride, and the pivots and metal-to-metal contact surfaces should be lubricated if necessary.



TIP

The switch built into the side stand is part of the ignition circuit cut-out system that cuts out the ignition in certain situations.



WARNING

Do not use the vehicle with the side stand lowered, or if it cannot be lifted correctly (or if it will not stay up), otherwise the side stand might not touch ground and distract the rider with the resulting possibility of losing control of the bike.

The cut-out ignition circuit has been designed to ensure the rider raises the side stand before putting the motorcycle in movement. Therefore, we ask that you check this system regularly, as described below, and have it repaired by a Benelli dealer if it does not operate correctly.

Checking the front fork

The condition and operation of the front fork must be checked as follows at the intervals specified in the periodic maintenance and lubrication chart.

To check the condition

Check the inner tubes for scratches, damage, and excessive oil leakage.

To check the operation

1. Place the vehicle on a flat surface and keep it upright.



WARNING

To avoid injury, securely support the vehicle so there is no danger of it falling over.

2. While applying the front brake, push down hard on the handlebars several times to check if the front fork compresses and rebounds smoothly.



NOTICE

If any damage is found or the front fork does not operate smoothly, have a Benelli dealer check or repair it.

Checking the steering

Worn or loose steering bearings may cause danger. Therefore, the operation of the steering must be checked as follows at the intervals specified in the periodic maintenance and lubrication chart.

1. Place the vehicle on a flat surface and keep it upright.



WARNING

To avoid injury, securely support the vehicle so there is no danger of it falling over.

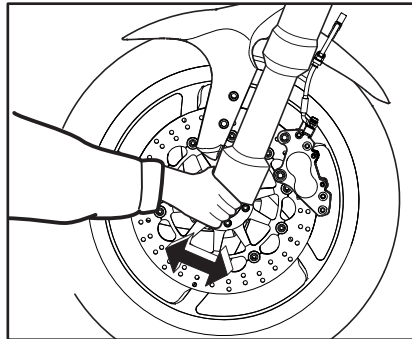

2. Hold the lower ends of the front fork legs and try to move them forward and backward. If any free play can be felt, have a Benelli dealer check or repair the steering.

Periodic maintenance and adjustment

Checking the wheel bearings

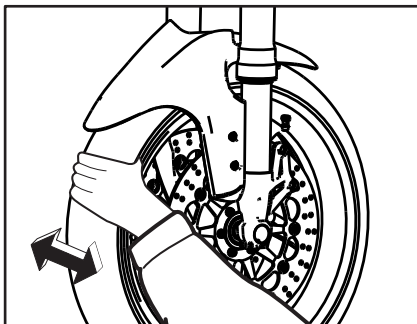

The front and rear wheel bearings must be checked at the intervals specified in the periodic maintenance and lubrication chart. If there is play in the wheel hub or if the wheel does not turn smoothly, have a Benelli dealer check the wheel bearings.

Battery

The battery is located under the seat. (See page 3-14).

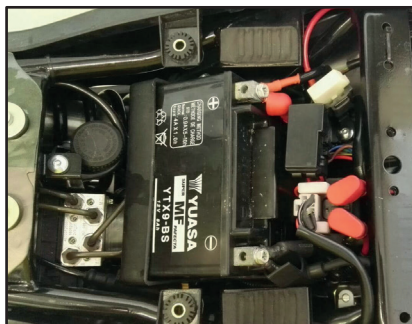

This model is equipped with a VRLA (Valve Regulated Lead Acid) battery. There is no need to check the electrolyte or to add distilled water. However, the battery lead connections need to be checked and, if necessary, tightened.

WARNING

- **Electrolyte is poisonous and dangerous since it contains sulfuric acid, which causes severe burns. Avoid any contact with skin, eyes or clothing and always shield your eyes when working near batteries. In case of contact, administer the following FIRST AID.**
 - **EXTERNAL:** Flush with plenty of water.
 - **INTERNAL:** Drink large quantities of water or milk and immediately call a physician.
 - **EYES:** Flush with water for 15 minutes and seek prompt medical attention.
- **Batteries produce explosive hydrogen gas. Therefore, keep sparks, flames, cigarettes, etc., away from the battery and provide sufficient ventilation when charging it in an enclosed space.**
- **KEEP THIS AND ALL BATTERIES OUT OF THE REACH OF CHILDREN.**

To charge the battery

Have a Benelli dealer charge the battery as soon as possible if it seems to have discharged. Keep in mind that the battery tends to discharge more quickly if the vehicle is equipped with optional electrical accessories.

NOTICE

To charge a VRLA (Valve Regulated Lead Acid) battery, a special (constant-voltage) battery charger is required. Using a conventional battery charger will damage the battery.

To store the battery

1. If the vehicle will not be used for more than one month, remove the battery, fully charge it, and then place it in a cool, dry place.

To remove the battery:

1. Remove the bolts and remove the battery clamp bracket after removing the starter relay and the fuse box from their position.

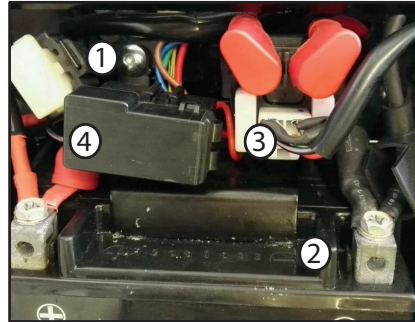

1. Bolts
2. Battery bracket
3. Starter relay
4. Fuse box

NOTICE

When removing the battery, be sure the key is turned to "OFF", then disconnect the negative lead before disconnecting the positive lead.

2. If the battery will be stored for more than two months, check it at least once a month and fully charge it if necessary.
3. Fully charge the battery before installation.

NOTICE

When installing the battery, be sure the key is turned to "OFF", then connect the positive lead before connecting the negative lead.

4. After installation, make sure that the battery leads are properly connected to the battery terminals.

NOTICE

Always keep the battery charged. Storing a discharged battery can cause permanent battery damage.

Periodic maintenance and adjustment

Replacing the fuses

The fuse box and individual fuses are located under the passenger seat. To access the fuse box and the main fuse remove the seat. (See page 3-15).

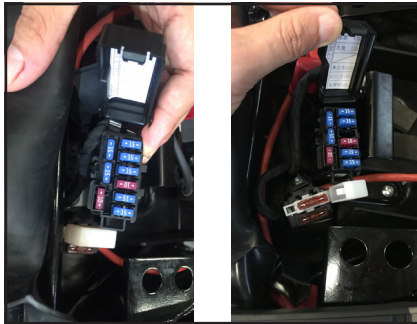

If a fuse is blown, replace it as follows.

1. Turn the key to "⊗" and turn off the electrical circuit in question.
2. Remove the blown fuse, and then install a new fuse of the specified amperage.



WARNING

Do not use a fuse of a higher amperage rating than recommended to avoid causing extensive damage to the electrical system and possibly a fire.

Without Headlight Switch

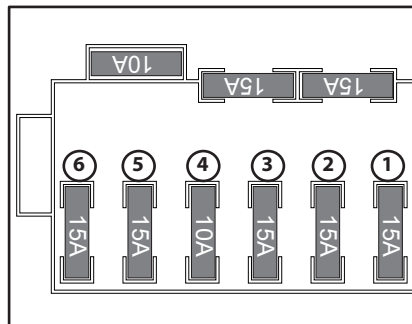

1. Fuel Pump
2. Fan
3. Headlights
4. Ignition Coil
5. ECU
6. Ignition Switch

With Headlight Switch

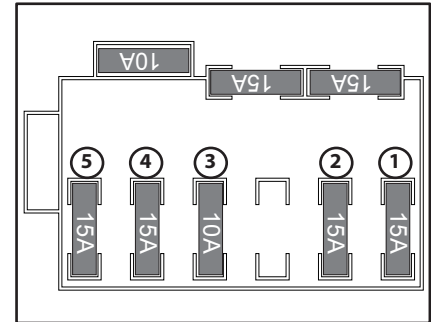

1. Fuel Pump
2. Fan
3. Ignition Coil
4. ECU
5. Ignition Switch

3. Turn the key to "⊙" and turn on the electrical circuit in question to check if the device operates.
4. If the fuse immediately blows again, have a Benelli dealer check the electrical system.

Brake/tail light and the turn signal light

This model is equipped with LED-type headlights and LED-type turn signal lights. If a headlight and turn signal light does not come on, check the fuses and then have a Benelli dealer check the vehicle.



1. Brake/tail light
2. Turn signal light

Auxiliary lights

This model is equipped with LED-type auxiliary lights. If an auxiliary light does not come on, have a Benelli dealer check the vehicle.



Troubleshooting

Although Benelli motorcycles receive a thorough inspection before shipment from the factory, trouble may occur during operation.

Any problem in the fuel, compression, or ignition systems, for example, can cause poor starting and loss of power.

The following troubleshooting charts represent quick and easy procedures for checking these vital systems yourself.

However, should your motorcycle require any repair, take it to a Benelli dealer, whose skilled technicians have the necessary tools, experience, and know-how to service the motorcycle properly.

Use only genuine Benelli replacement parts.

Imitation parts may look like Benelli parts, but they are often inferior, have a shorter service life and can lead to expensive repair bills.

Periodic maintenance and adjustment



WARNING

When checking the fuel system, do not smoke, and make sure there are no open flames or sparks in the area, including pilot lights from water heaters or furnaces.

Gasoline or gasoline vapors can ignite or explode, causing severe injury or property damage.

Troubleshooting charts

Starting problems or poor engine performance

1. Fuel

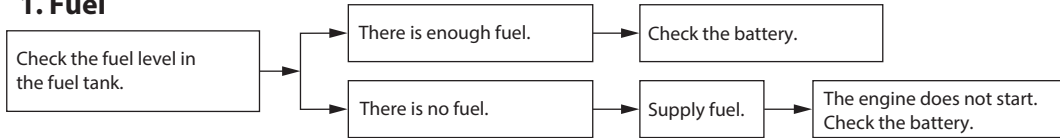

2. Battery

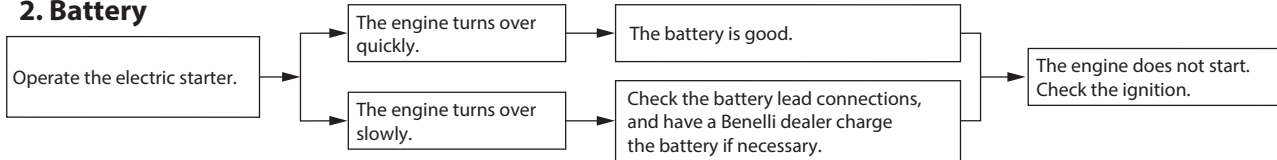

3. Ignition

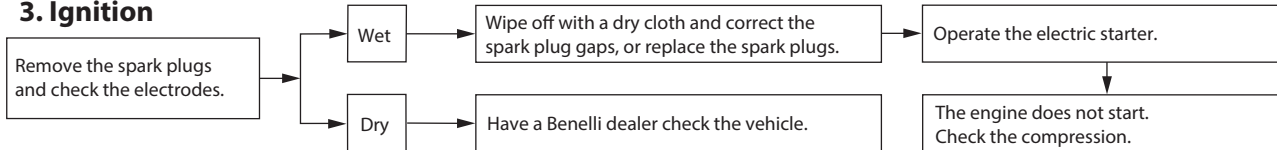

4. Compression

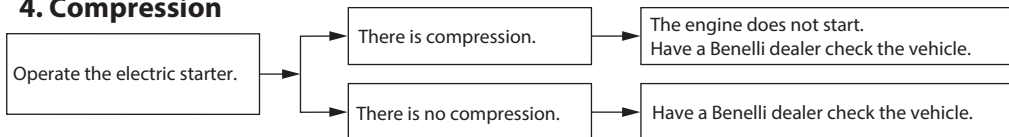

Periodic maintenance and adjustment

Engine overheating

WARNING

- **Do not remove the radiator cap when the engine and radiator are hot. Scalding hot fluid and steam may be blown out under pressure, which could cause serious injury. Be sure to wait until the engine has cooled.**
- **Place a thick rag, like a towel, over the radiator cap, and then slowly rotate the cap counterclockwise to the detent to allow any residual pressure to escape.**
- **When the hissing sound has stopped, press down on the cap while turning it counterclockwise, and then remove the cap.**

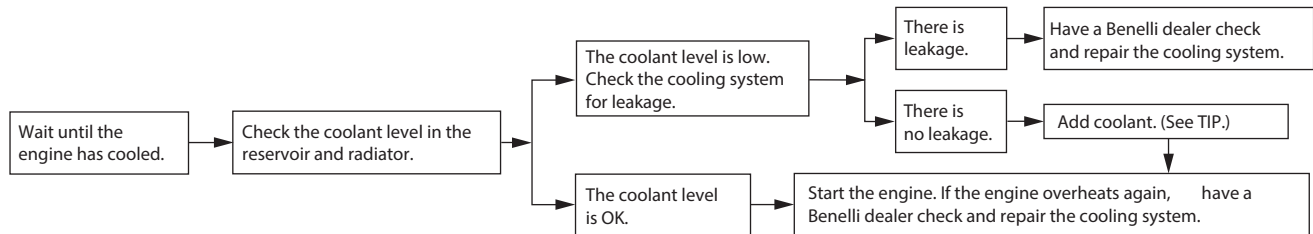

TIP

If coolant is not available, tap water can be temporarily used instead, provided that it is changed to the recommended coolant as soon as possible.

Matte color caution

NOTICE

Some models are equipped with matte colored finished parts. Be sure to consult a Benelli dealer for advice on what products to use before cleaning the vehicle.

Using a brush, harsh chemical products or cleaning compounds when cleaning these parts will scratch or damage their surface. Wax also should not be applied to any matte colored finished parts.

Care

While the open design of a motorcycle reveals the attractiveness of the technology, it also makes it more vulnerable.

Rust and corrosion can develop even if high-quality components are used.

A rusty exhaust pipe may go unnoticed on a car, however, it detracts from the overall appearance of a motorcycle.

Frequent and proper care does not only comply with the terms of the warranty, but it will also keep your motorcycle looking good, extend its life, and optimize its performance.

Before cleaning

1. Cover the muffler outlet with a plastic bag after the engine has cooled down.
2. Make sure that all caps and covers as well as all electrical couplers and connectors, including the spark plug caps, are tightly installed.
3. Remove extremely stubborn dirt, like oil burnt onto the crankcase, with a degreasing agent and a brush, but never apply such products onto seals, gaskets, sprockets, the drive chain and wheel axles. Always rinse the dirt and degreaser off with water.

Cleaning

NOTICE

- **Avoid using strong acidic wheel cleaners, especially on spoked wheels. If such products are used on hard-to-remove dirt, do not leave the cleaner on the affected area any longer than instructed. Also, thoroughly rinse the area off with water, immediately dry it, and then apply a corrosion protection spray.**
- **Improper cleaning can damage plastic parts (such as cowlings, panels, windshields, headlight lenses, meter lenses, etc.) and the mufflers. Use only a soft, clean cloth or sponge with water to clean plastic. However, if the plastic parts cannot be thoroughly cleaned with water, diluted mild detergent with water may be used. Be sure to rinse off any detergent residue using plenty of water, as it is harmful to plastic parts.**
- **Do not use any harsh chemical products on plastic parts. Be sure to avoid using cloths or sponges which have been in contact with strong or abrasive cleaning products, solvent or thinner, fuel**

Motorcycle care and storage

(gasoline), rust removers or inhibitors, brake fluid, antifreeze or electrolyte.

- **Do not use high-pressure washers or steam-jet cleaners since they cause water seepage and deterioration in the following areas: seals (of wheel and swingarm bearings, fork and brakes), electric components (couplers, connectors, instruments, switches and lights), breather hoses and vents.**
- **For motorcycles equipped with a windshield: Do not use strong cleaners or hard sponges as they will cause dulling or scratching. Some cleaning compounds for plastic may leave scratches on the windshield. Test the product on a small hidden part of the windshield to make sure that it does not leave any marks. If the windshield is scratched, use a quality plastic polishing compound after washing.**

After normal use

Remove dirt with warm water, a mild detergent, and a soft, clean sponge, and then rinse thoroughly with clean water. Use a toothbrush or bottlebrush for hard-to-reach areas. Stubborn dirt and insects will come off more easily if the area is covered with a wet cloth for a few minutes before cleaning.

After riding in the rain, near the sea or on salt-sprayed roads

Since sea salt or salt sprayed on roads during winter are extremely corrosive in combination with water, carry out the following steps after each ride in the rain, near the sea or on salt-sprayed roads.

TIP

Salt sprayed on roads in the winter may remain well into spring.

1. Clean the motorcycle with cold water and a mild detergent, after the engine has cooled down.

NOTICE

Do not use warm water since it increases the corrosive action of the salt

Apply a corrosion protection spray on all metal, including chrome and nickel-plated, surfaces to prevent corrosion.

After cleaning

1. Dry the motorcycle with a chamois or an absorbent cloth.
2. Immediately dry the drive chain and lubricate it to prevent it from rusting.
3. Use a chrome polish to shine chrome, aluminum and stainless-steel parts, including the exhaust system. (Even the thermally induced discoloring of stainless-steel exhaust systems can be removed through polishing.)
4. To prevent corrosion, it is recommended to apply a corrosion protection spray on all metal, including chrome and nickel plated, surfaces.
5. Use spray oil as a universal cleaner to remove any remaining dirt.
6. Touch up minor paint damage caused by stones, etc.
7. Wax all painted surfaces.
8. Let the motorcycle dry completely before storing or covering it.



WARNING

Contaminants on the brakes or tires can cause loss of control.

- **Make sure that there is no oil or wax on the brakes or tires.**
- **If necessary, clean the brake discs and brake linings with a regular brake disc cleaner or acetone, and**

wash the tires with warm water and a mild detergent. Before riding at higher speeds, test the motorcycle's braking performance and cornering behavior.

NOTICE

- Apply spray oil and wax sparingly and make sure to wipe off any excess.
- Never apply oil or wax to any rubber and plastic parts, but treat them with a suitable care product.
- Avoid using abrasive polishing compounds as they will wear away the paint.

TIP

- Consult a Benelli dealer for advice on what products to use.
- Washing, rainy weather or humid climates can cause the headlight lens to fog. Turning the headlight on for a short period of time will help remove the moisture from the lens.

Storage

Short-term

Always store your motorcycle in a cool, dry place and, if necessary, protect it against dust with a porous cover. Be sure the engine and the exhaust system are cool before covering the motorcycle.

NOTICE

- Storing the motorcycle in a poorly ventilated room or covering it with a tarp, while it is still wet, will allow water and humidity to seep in and cause rust.
- To prevent corrosion, avoid damp cellars, stables (because of the presence of ammonia) and areas where strong chemicals are stored.

Long-term

Before storing your motorcycle for several months:

- Follow all the instructions in the "Care" section of this chapter.
- Fill up the fuel tank and add fuel stabilizer (if available) to prevent the fuel tank from rusting and the fuel from deteriorating.
- Perform the following steps to protect the cylinders, piston rings, etc. from corrosion.
 - Remove the spark plug caps and spark plugs.
 - Pour a teaspoonful of engine oil into each spark plug bore.
 - Install the spark plug caps onto the spark plugs, and then place the spark plugs on the cylinder head so that the electrodes are grounded. (This will limit sparking during the next step.)
 - Turn the engine over several times with the starter. (This will coat the cylinder walls with oil.)

Motorcycle care and storage



WARNING

To prevent damage or injury from sparking, make sure to ground the spark plug electrodes while turning the engine over.

- Remove the spark plug caps from the spark plugs, and then install the spark plugs and the spark plug caps.
- Lubricate all control cables and the pivoting points of all levers and pedals as well as of the sidestand
- Check and, if necessary, correct the tire air pressure, and then lift the motorcycle so that both of its wheels are off the ground. Alternatively, turn the wheels a little every month in order to prevent the tires from becoming degraded in one spot.
- Cover the muffler outlet with a plastic bag to prevent moisture from entering it.
- Remove the battery and fully charge it. Store it in a cool, dry place and charge it once a month. Do not store the battery in an excessively cold or warm place. For more information on storing the battery, see page 6-29.

TIP

Make any necessary repairs before storing the motorcycle.

Dimensions:

Overall length:

2160 mm

Overall width:

875 mm

Overall height:

1160 mm

Wheelbase:

1460 mm

Seat height:

815 mm

Trail Dimensions:

Overall length:

2180 mm

Overall width:

875 mm

Overall height:

1200 mm

Wheelbase:

1470 mm

Seat height:

835 mm

Weight:

Curb weight:

207 kg (456 lbs)

Engine:

Combustion cycle:

4-stroke

Cooling system:

liquid cooled

Valve train:

DOHC

Cylinder arrangement:

Vertically

Number of cylinders:

2 cylinders

Displacement:

500 cm³

Bore x stroke:

69 x 66.8 mm

Compression ratio:

11.5 : 1

Starting system:

Electric starter

Lubrication system:

Wet sump

Engine oil:

SAE viscosity grades:

10W-50

Recommended engine oil grade:

API SJ-JASO MA2

Engine oil quantity:

Oil change:

2.9 L

With oil filter removal:

3.0 L

Coolant quantity:

Coolant reservoir (up to the maximum level mark):

0.3 L

Radiator (including all hoses):

2.4 L

Air filter:

Air filter element:

Paper filtering element

Fuel:

Recommended fuel:

Premium unleaded gasoline (91 octane or higher)

Fuel tank capacity:

12.7 L ± 0.5L (3.35 gal)

Fuel reserve amount:

1.3 L (0.34 gal)

Fuel consumption:

4,3 l/100 km

CO² emissions:

100 g/km

Spark plugs:

Manufacturer/model:

NGK CR8E

Spark plug gap:

0.7–0.8 mm

Specifications

Clutch:

Clutch type:

Wet, multiple-disc

Transmission:

Final drive:

Chain

Transmission type:

Constant mesh 6-speed

Chassis:

Frame type:

Trellis pipes with steel plates

Front tire:

Type:

Tubeless

Size:

120/70 ZR17 M/C 58W

Trail front tire:

Type:

Tube-type

Size:

110 /80 ZR19 M/C 59V

Rear tire:

Type:

Tubeless

Size:

160/60 ZR17 M/C 69W

Trail rear tire:

Type:

Tube-type

Size:

150 /70 ZR17 M/C 69V

Loading:

Maximum load: 190 Kg (418 lbs)

* (Total weight of rider, passenger, cargo and accessories)

Tire air pressure (measured on cold tires):

Front:

220 ± 10 kPa (32 psi)

Rear:

250 ± 10 kPa (36 psi)

Front wheel:

Wheel type:

Aluminium alloy

Rim size:

17 x 3.50

Trail front wheel:

Wheel type:

Spoked rim

Rim size:

19 x 3.00

Rear wheel:

Wheel type:

Aluminium alloy

Rim size:

17 x 4.50

Trail Rear wheel:

Wheel type:

Spoked rim

Rim size:

17 x 4.25

Front brake:

Type:

Double semi-floating disc with 4-piston radial calliper and ABS

Ø Disc:

320 mm

Specified brake fluid:

DOT 4

Rear brake:

Type:

Single disc with single piston floating caliper and ABS

Ø Disc:

260 mm

Specified brake fluid:

DOT 4

Front suspension:

Type:

Upside-down Fork

Shock absorber:

Hydraulic damper

Wheel travel:

125 mm

Trail wheel travel:

135 mm

Rear suspension:

Type:

Oscillating swingarm with side mono-shock adjustable spring preload and compression dampening

Shock absorber:

Hydraulic damper

Electrical system:

System voltage:

12 V

Ignition system:

ECU - BOSCH MSE6.0

Charging system:

AC magneto

Battery:

Model:

YTX9-BS

Voltage, capacity:

12V 8Ah

Bulb wattage:

Headlight:

LED

Brake/tail light:

LED

Front turn signal light:

LED

Rear turn signal light:

LED

Meter lighting:

LED

Neutral indicator light:

LED

Hight beam indicator light:

LED

Oil pressure warning light:

LED

Turn signal indicator light:

LED

Engine trouble warning light:

LED

ABS warning light:

LED

Fuse(s):

Fuel Pump fuse:

15.0 A

Fan fuse:

15.0 A

Headlights fuse:

15.0 A

Ignition Coil fuse:

10.0 A

ECU fuse:

15.0 A

Ignition switch

fuse: 15.0 A

ABS motor fuse:

40.0 A

Specifications

Electrical System

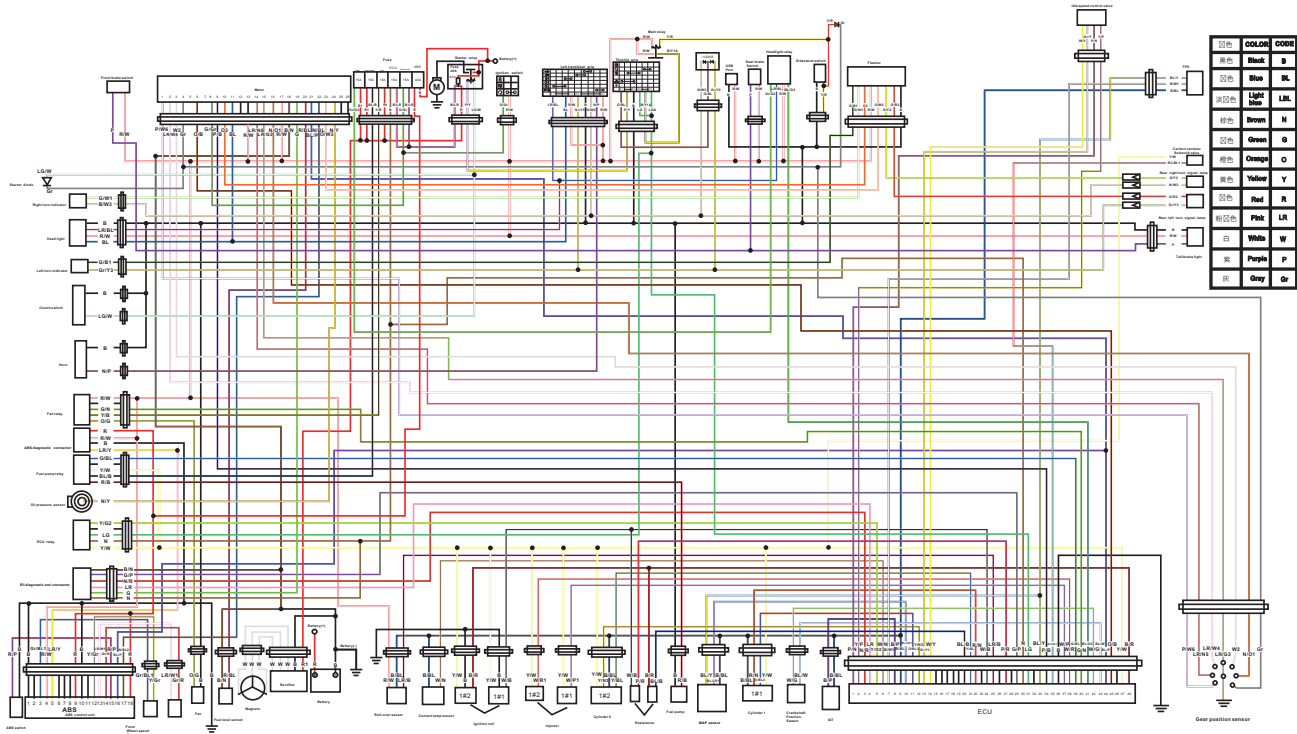

Identification numbers

Record the vehicle identification number, engine serial number, and the model label information in the spaces provided below. These identification numbers are needed when registering the vehicle with the authorities in your area and when ordering spare parts from a Benelli dealer.

VEHICLE IDENTIFICATION NUMBER:

ENGINE SERIAL NUMBER:

MODEL LABEL INFORMATION:

Vehicle identification number

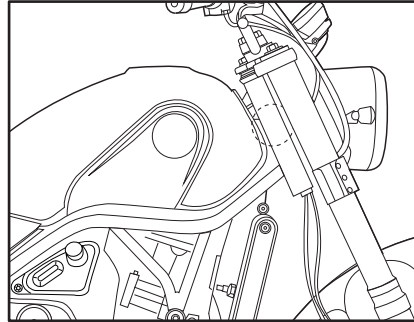

The identification number of the vehicle is punched on the steering head; this number is registered with the relevant authorities for the area concerned. Record this number in the space provided.

Engine serial number



The engine serial number is punched on the engine casing, to the right side of the rider and is the construction serial number of the engine. Record this number in the space provided.

Consumer information

Model label



The model label is applied to the left side of the steering head. Record the information on this label in the space provided. This information will be needed when ordering spare parts from a Benelli dealer.

WARNING

Any changes to the ID number stamped on the frame or engine will automatically render the warranty null and void.

Diagnostic connector

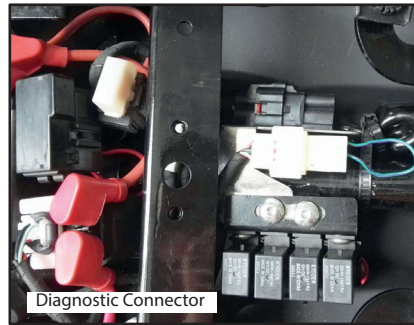

The diagnostic connector is located as shown.

Vehicle data recording

This model's ECU stores certain vehicle data to assist in the diagnosis of malfunctions and for research and development purposes.

This data will be uploaded only when a special Benelli diagnostic tool is attached to the vehicle, such as when maintenance checks or service procedures are performed.

Although the sensors and recorded data will vary by model, the main data points are:

- Vehicle status and engine performance data
- Fuel-injection and emission-related data

Benelli will not disclose this data to a third party except:

- With the consent of the vehicle owner
- Where obligated by law
- For use by Benelli in litigation
- For general Benelli-conducted research purposes when the data is not related to an individual vehicle nor owner.

Regular maintenance coupons

COUPON N. 1 -

Model/Cubic capacity

Dealer's stamp

Frame number, in full

Miles travelled

SERVICE CARRIED OUT USING REMOTE MEANS

OK

Responsibility of the dealer

The vehicle has been inspected, following all of the operations outlined in the maintenance plan.

Signature _____

Responsibility of the owner

The service was completed to your satisfaction.

Date _____

Signature _____

This service involves (C= Checks / S= Replacement)

- Rear shock absorber
- Spark plugs
- Transmission chain
- Side stand
- Fuel circuit
- Wheel bearings
- Steering bearings

- Air Filter
- Oil Filter
- Rear brake
- Front brake
- Valve clearance
- Brake Fluid
- Coolant
- Lights, signals and switches

- Throttle
- Exhaust
- Swingarm pivot
- Engine oil
- Tires
- Bolt torque
- Fuel hoses
- ABS System

Regular maintenance coupons

COUPON N. 2 -

Model/Cubic capacity

Frame number, in full

Miles travelled

Dealer's stamp

SERVICE CARRIED OUT USING REMOTE MEANS

OK

Responsibility of the dealer

The vehicle has been inspected, following all of the operations outlined in the maintenance plan.

Signature _____

Date _____

Responsibility of the owner

The service was completed to your satisfaction.

Signature _____

This service involves (C= Checks / S= Replacement)

- Rear shock absorber
- Spark plugs
- Transmission chain
- Side stand
- Fuel circuit
- Wheel bearings
- Steering bearings

- Air Filter
- Oil Filter
- Rear brake
- Front brake
- Valve clearance
- Brake Fluid
- Coolant
- Lights, signals and switches

- Throttle
- Exhaust
- Swingarm pivot
- Engine oil
- Tires
- Bolt torque
- Fuel hoses
- ABS System

Regular maintenance coupons

COUPON N. 3 -

Model/Cubic capacity

Dealer's stamp

Frame number, in full

Miles travelled

SERVICE CARRIED OUT USING REMOTE MEANS

OK

Responsibility of the dealer

The vehicle has been inspected, following all of the operations outlined in the maintenance plan.

Signature _____

Date _____

Responsibility of the owner

The service was completed to your satisfaction.

Signature _____

This service involves (C= Checks / S= Replacement)

- Rear shock absorber
- Spark plugs
- Transmission chain
- Side stand
- Fuel circuit
- Wheel bearings
- Steering bearings

- Air Filter
- Oil Filter
- Rear brake
- Front brake
- Valve clearance
- Brake Fluid
- Coolant
- Lights, signals and switches

- Throttle
- Exhaust
- Swingarm pivot
- Engine oil
- Tires
- Bolt torque
- Fuel hoses
- ABS System

Regular maintenance coupons

COUPON N. 4 -

Model/Cubic capacity

Frame number, in full

Miles travelled

Dealer's stamp

SERVICE CARRIED OUT USING REMOTE MEANS

OK

Responsibility of the dealer

The vehicle has been inspected, following all of the operations outlined in the maintenance plan.

Signature _____

Date _____

Responsibility of the owner

The service was completed to your satisfaction.

Signature _____

This service involves (C= Checks / S= Replacement)

- Rear shock absorber
- Spark plugs
- Transmission chain
- Side stand
- Fuel circuit
- Wheel bearings
- Steering bearings

- Air Filter
- Oil Filter
- Rear brake
- Front brake
- Valve clearance
- Brake Fluid
- Coolant
- Lights, signals and switches

- Throttle
- Exhaust
- Swingarm pivot
- Engine oil
- Tires
- Bolt torque
- Fuel hoses
- ABS System

Regular maintenance coupons

COUPON N. 5 -

Model/Cubic capacity

Dealer's stamp

Frame number, in full

Miles travelled

SERVICE CARRIED OUT USING REMOTE MEANS

OK

Responsibility of the dealer

The vehicle has been inspected, following all of the operations outlined in the maintenance plan.

Signature _____

Date _____

Responsibility of the owner

The service was completed to your satisfaction.

Signature _____

This service involves (C= Checks / S= Replacement)

- Rear shock absorber
- Spark plugs
- Transmission chain
- Side stand
- Fuel circuit
- Wheel bearings
- Steering bearings

- Air Filter
- Oil Filter
- Rear brake
- Front brake
- Valve clearance
- Brake Fluid
- Coolant
- Lights, signals and switches

- Throttle
- Exhaust
- Swingarm pivot
- Engine oil
- Tires
- Bolt torque
- Fuel hoses
- ABS System

Emission Control System Warranty

EMISSION CONTROL SYSTEM WARRANTY

YOUR WARRANTY RIGHTS AND OBLIGATIONS

The California Air Resources Board, the U.S. Environmental Protection Agency, and SSR MOTORSPORTS. (hereinafter "SSR") are pleased to explain the Emission Related Components warranty on your 2021 Highway Motorcycle. New highway motor vehicles must be designed, built and equipped to meet U.S. EPA Federal and California anti-smog standards. SSR must warrant the Emission Related Components on your vehicle for 12,000mi or for 5 years, whichever comes first, provided that there has been no abuse, neglect or improper maintenance of your vehicle. Your emission control system may include parts such as the carburetor or fuel injection system, the ignition system, catalytic converter and engine computer, if it is equipped. Also included may be hoses, belts, connectors and other emission-related assemblies. Where a warrantable condition exists, SSR will repair your vehicle at no cost to you, including diagnosis, parts and labor. If an emission-related part on your vehicle is defective, the part will be repaired or replaced by SSR. This is your emission control system DEFECTS WARRANTY.

OWNER'S WARRANTY RESPONSIBILITIES

As the vehicle owner, you are responsible for the performance of the required maintenance listed in your owner's manual. SSR recommends that you retain all receipts covering maintenance on your vehicle, but SSR cannot deny warranty solely for the lack of receipts or for your failure to ensure the performance of all scheduled maintenance.

You are responsible for presenting your vehicle to the SSR dealer as soon as a problem exists. The warranty repairs should be completed in a reasonable amount of time, not to exceed 30 days. As the vehicle owner, you should be aware that SSR may deny your warranty coverage if your vehicle or a part has failed due to abuse, neglect, improper maintenance or unapproved modifications. If you use your vehicle in any type of competitive event, this warranty is immediately and completely void.

If you have any questions regarding your warranty rights and responsibilities, you should contact SSR MOTORSPORTS, 13220 Molette St., Santa Fe Springs, CA 90670 TEL: 562-926-2888 or (for California registered highway vehicles only) the California Air Resources Board at 9528 Telstar Avenue, El Monte, CA 91731-8001. SSR warrants that each new 2021 and later SSR highway motorcycle:

A: is designed, built and equipped so as to conform at the time of initial retail purchase with all applicable regulations of the United States Environmental Protection Agency, and the California Air Resources Board;
and

B: is free from defects in material and workmanship which cause such vehicle to fail to conform with applicable regulations of the United States Environmental Protection Agency or the California Air Resources Board for the periods specified above.

I. COVERAGE

Warranty defects shall be remedied during customary business hours at any authorized SSR' dealer located within the United States of America in compliance with the Clean Air Act and applicable regulations of the United States Environmental Protection Agency and the California Air Resources Board. Any part or parts replaced under this warranty shall become the property of SSR.

II. LIMITATIONS

This Emission Control System Warranty shall not cover any of the following:

A. Repair or replacement as a result of

- (1) accident,
- (2) misuse,
- (3) repairs improperly performed or replacements improperly installed,
- (4) use of replacement parts or accessories not conforming to SSR' specifications which adversely affect performance and/or
- (5) use in competitive racing or related events.

B. Inspections, replacement of parts and other services and adjustments required for required maintenance.

C. Any vehicle equipped with an odometer or hour meter on which the odometer mileage or hour meter reading has been changed so that actual mileage cannot be readily determined.

III. LIMITED LIABILITY

A. The liability of SSR under this emission control system warranty is limited solely to the remedying of defects in material or workmanship by an authorized SSR' dealer at its place of business during customary business hours. This warranty does not cover inconvenience or loss of use of the vehicle or transportation of the vehicle to or from the SSR' dealer. SSR shall not be liable for any other expenses, loss or damage, whether direct, incidental, consequential or exemplary arising in connection with the sale or use of or inability to use the vehicle for any purpose. Some states do not allow the exclusion or limitation of any incidental or consequential damages, so the above limitations may not apply to you.

B. No express emission control system warranty is given by us except as specifically set forth herein. Any emission control system warranty implied by law, including any warranty of merchantability or fitness for a particular purpose, is limited to the express emission control system warranty terms stated in this warranty. The foregoing statements of warranty are exclusive and in line of all other remedies. Some states do not allow limitations on how long an implied warranty lasts so the above limitations may not apply to you.

C. No dealer is authorized to modify this SSR Limited Emission Control System Warranty.

IV. LEGAL RIGHTS

This warranty gives you specific legal rights, and you may also have other rights which vary from state to state.

Emission Control System Warranty

V. THIS EMISSION CONTROL SYSTEM WARRANTY IS IN ADDITION TO THE STANDARD LIMITED WARRANTY FOR ALL VEHICLES.

VI. ADDITIONAL INFORMATION

Any replacement part that is equivalent in performance and durability may be used in the performance of any maintenance or repairs. However, SSR is not liable for these parts. The owner is responsible for the performance of all required maintenance. Such maintenance may be performed at a service establishment or by any individual. The warranty period begins on the date the motorcycle is delivered to an ultimate purchaser.

02401P180001

Benelli Q.J. s.r.l.

Strada della Fornace Vecchia, sn - 61122 Pesaro Italy

Tel. +39 0721 41871 Fax +39 0721 418722

support@benelli.com / www.benelli.com / www.benellishop.com

